

## Physicians' attitude scale towards doping: A scale development study

### Hekimlerde dopinge yönelik tutum ölçeği: Bir ölçek geliştirme çalışması

Aydan Örsçelik<sup>1</sup> , Sabriye Ercan<sup>2</sup> 

<sup>1</sup>Health Sciences University Gulhane Medical Faculty Sports Medicine Department, Ankara, Turkey

<sup>2</sup>Faculty of Medicine, Süleyman Demirel University, Sports Medicine Department, Isparta, Turkey

#### ABSTRACT

**Objective:** To develop the "Physicians' Attitude Scale towards Doping" and provide the validity and reliability of the scale in Turkish physicians.

**Material and Methods:** This quantitative research design study followed the scale development study procedures. Initially, the 47-items pool was submitted for academicians' expert opinion. Thirty-two items with a content validity ratio value below 0.56 were removed from the scale after expert opinion. Thus, the content validity ratio was calculated as 0.67-1.00, and the content validity index was 0.844. After the expert opinion, the pilot-scale with 15 items was applied to the physicians by reaching the sample size of at least 10 times the number of items. According to the answers given to the pilot scale, validity and reliability analyzes of the scale were made.

**Results:** A 15-item pilot scale was applied to 292 physicians. Four items that reduce the Cronbach's alpha coefficient and an item with a value below 0.30 in the extraction column of the communalities table were excluded from the scale. Item discrimination index values of the scale were found to be appropriate ( $p < 0.001$ ). All of the item load distributions were found above 0.50, and the item quality was good. The total variance rate explained by this factor is 59.3%. Cronbach's alpha reliability coefficient of the whole scale was calculated as 0.761. The fit indices of the model tested with confirmatory factor analysis were good.

**Conclusion:** The "Physicians' Attitude Scale towards Doping" was developed, and the validity and reliability of the two factor and total 10-item scale were provided.

**Keywords:** Doping, attitude, scale development

#### ÖZ

**Amaç:** 'Hekimlerde Dopinge Yönelik Tutum Ölçeği'ni geliştirmek, ölçeğin geçerliğini ve güvenilirliğini Türk hekimlerinde sağlamaktır.

**Gereç ve Yöntem:** Nicel araştırma desenindeki bu çalışmada, ölçek geliştirme çalışmaları için önerilen işlem basamakları takip edildi. Başlangıçta 47 maddeden oluşan madde havuzu uzman görüşüne sunuldu. Kapsam geçerlilik oranı 0.56'nın altında olan 32 madde uzman görüşü alınarak ölçekten çıkarıldı. Böylece maddelerin kapsam geçerlilik oranı 0.67-1.00, ölçeğin kapsam geçerlilik indeksi ise 0.844 olarak hesaplandı. Uzman görüşünün alınmasının ardından 15 maddelik pilot ölçek, madde sayısının en az 10 katı büyüklüğündeki örneklem sayısına ulaşılarak hekimlere uygulandı. Pilot ölçeğe verilen yanıtlara göre ölçeğin geçerlik ve güvenilirlik analizleri yapıldı.

**Bulgular:** Toplam 15 soruluk pilot ölçek 292 hekime uygulandı. Cronbach alfa katsayısını düşüren dört madde ve ortak yükler (Communalities) tablosunun çıkarım (Extraction) sütununda değeri 0.30'un altında kalan bir madde ölçekten çıkarıldı. Ölçeğin madde ayırt ediciliği indeksi değerleri uygun bulundu ( $p < 0.001$ ). Madde yük dağılımlarının tümü 0.50'nin üstünde bulunarak madde kalitesi iyi düzeyde oldu. Ölçekte kalan 10 madde iki faktör altında toplandı. Bu faktörün açıkladığı toplam varyans oranı %59.3'tü. Ölçeğin bütünü Cronbach alfa güvenilirlik katsayısı 0.761 olarak hesaplandı. Doğrulayıcı faktör analizi ile sınanan modelin uyum indeksleri iyi düzeyde bulundu.

**Sonuç:** 'Hekimlerde Dopinge Yönelik Tutum Ölçeği' geliştirilerek, iki faktörlü ve toplam 10 maddeli ölçeğin geçerliği ve güvenilirliği sağlandı.

**Anahtar Sözcükler:** Doping, tutum, ölçek geliştirme

#### INTRODUCTION

Doping is defined as the occurrence of one or more of the anti-doping rule violations such as "the presence of a prohibited substance or its metabolites or markers in an athlete's sample; use or attempted use by an athlete of a prohibited substance or a prohibited method; evading, refusing or failing to submit to sample collection; whereabouts failures by an athlete; tampering or attempted tampering with any part of doping control by an athlete or other person; pos-

session of a prohibited substance or a prohibited method by an athlete or athlete support person; trafficking or attempted trafficking in any prohibited substance or prohibited method by an athlete or other person; administration or attempted administration by an athlete or other person to any athlete in-competition of any prohibited substance or prohibited method, or administration or attempted administration to any athlete out-of-competition of any prohibi-

Received: 14.10.2021 · Accepted: 12.12.2021 · Published: 23.03.2022 · Issue: September 2022

Correspondence / Yazışma: Aydan Örsçelik · Sağlık Bilimleri Üniversitesi, Gülhane Tıp Fakültesi, Spor Hekimliği Bölümü, Ankara, Turkey · aydanozcan@yahoo.com

Örsçelik A, Ercan S. Physicians' attitude scale towards doping: A scale development study. *Turk J Sports Med.* 2022, 57(3):129-35; <http://doi.org/10.47447/tjism.0629>

© 2022 Turkish Sports Medicine Association. All rights reserved.

This is an open access article under the terms of the Creative Commons Attribution-NonCommercial License, which permits use, distribution and reproduction in any medium, provided the original work is properly cited and is not used for commercial purposes (<http://creativecommons.org/licenses/by-nc/4.0/>).

ted substance or any prohibited method that is prohibited out-of-competition; complicity or attempted complicity by an athlete or other person; and prohibited association by an athlete or other person, acts by an athlete or other person to discourage or retaliate against reporting to authorities' perpetration of one or more of the anti-doping rule violations" (1).

Athletes often resort to this forbidden behavior with performance enhancement anxiety. However, anti-doping programs aim to protect what is fundamentally valuable to sport, namely the 'spirit of sport', to prohibit doping (2-4). The international sports and amateur athletics federations were the first organizations to fight against doping and prohibited certain doping substances in 1928. The International Olympic Committee (IOC) has pioneered anti-doping since the 1960s and created a prohibited list for Olympic sports. The World Anti-Doping Agency (WADA) took over this post from the IOC in 2004. It regulates the prohibited list, published annually, and includes all Olympic sports and almost all international federations (5). Under various headings, the aforementioned organizations have been established to prevent doping for years worldwide. Because doping disrupts the concept of equality in the game, it also harms the athlete's health and harms concepts such as respect for others, teamwork, earning by deserving, and the spirit of sports. The term "spirit of sport" includes and describes the principles of ethics, fair play, and honesty (6).

The use of prohibited substances is a severe problem in athletes, either knowingly or unknowingly. It mediates an illegal competitive advantage in sport and causes many metabolic or systemic diseases, including an increased risk of death (7). For this reason, a physician may not use prohibited substances and methods on the athlete for non-therapeutic purposes(2,4,5). In any case, it is not ethical to use substances and methods that are described as performance enhancers in individuals engaged in sports (2). However, for the necessary and suitable usage of the medical conditions that are not considered doping, there are criteria described in the International Standard Therapeutic Use Exemption (TUE).

TUE is provided to athletes use, if they meet conditions such as 'the prohibited substance or prohibited method in question is needed to treat a diagnosed medical condition supported by relevant clinical evidence, the therapeutic use of the prohibited substance or prohibited method will not, on the balance of probabilities, produce any additional enhancement of performance beyond what might be anticipated by a return to the athlete's normal state of health following the treatment of the medical condition, the prohibited substance or prohibited method is an indicated treat-

ment for the medical condition, there is no reasonable permitted therapeutic alternative, and the necessity for the use of the prohibited substance or prohibited method is not a consequence, wholly or in part, of the prior use (without a TUE) of a substance or method which was prohibited at the time of such use' (4,5,8,9).

On the other hand, both sports medicine and other physicians will have difficulties all the time, both ethically and medically, when making medical decisions for athletes. Unfortunately, clear decisions about doping are not always resolved easily by whether or not a substance is listed. It requires more complexity, more knowledge, and a broader perspective (5). Physicians should encourage clean play, respect for sports spirit, and rules for healthy athletes by good medical practice (5). Although physicians regularly face doping in their daily routines (10), studies (2,11-14) reveal that they do not have sufficient knowledge about doping.

Anabolic agents were one of the first prohibited substances in sports history (2). Nevertheless, the British Medical Association reported that steroid abuse is a public health risk in 2002. Half of the athletes who do bodybuilding at the gyms use anabolic agents such as steroids, which is widely known. Steroid usage was 13% in some street sports, and it was found that one-third of all general practitioners treat patients taking steroids (15). Similarly, in a study involving 400 general practitioners in the UK, 12% claimed that they were entitled to prescribe anabolic steroids for non-medical reasons, and about 87% of French general practitioners consider doping as a public health problem. Although 83% saw their training as insufficient in this area, 92% thought they were important in preventing doping (10).

"It is the physician's responsibility to take care of the health and well-being of athletes, to evaluate their performance capacity, to give nutritional advice, to prescribe and monitor substance use" (4). Physicians must have information about the fight against doping, and reflect an anti-doping attitude in protecting athletes' health (4), and to achieve this, it is necessary to have sufficient knowledge about doping and consider the fight against doping as a duty.

Although many studies and scales (16-20) examine athletes' attitudes towards doping in the literature, the number of studies assessing physicians' attitudes towards doping is limited, and no measurement tool can measure physicians' attitudes towards doping. This study aims to develop a "Physicians attitude scale towards doping".

## **MATERIALS and METHODS**

This research was designed as a scale development study and conducted using a quantitative research design (16).

The local ethics committee dated 17/02/2021 and numbered 102. For expert opinion, a measurement tool's two most essential features should be validity and reliability. Several steps are recommended during scale development studies to achieve these features. The first is to create a comprehensive item pool that will reflect the basic sub-dimensions obtained from the literature review, and secondly to seek expert opinion to examine the content validity of this item pool (16).

A literature review was done for the "Physicians' Attitude Scale towards Doping" and an item pool consisting of 47 items was created by the researchers. Expert opinion was obtained according to the Lawshe method to evaluate the item pool created by the researchers (xx, yy) (16). Twelve experts evaluated the content validity of the scale. To examine the content validity of the scale, four (33.3%) sports medicine experts, four (33.3%) sports sciences specialists, an expert (8.3%) in each of the areas of psychiatry, psychology, public health, and molecular biology and genetics were consulted. The mean experience period of the experts whose opinions were taken was  $18.7 \pm 13.0$  years. Experts have assessed the clarity and relevance of questions on the scale.

**Scope (content) validity:** Since the number of experts with opinions is 12, the lowest content validity ratio (CVR) value for  $\alpha=0.05$  significance level was accepted as 0.56 (16). Thirty-two items with a CVR value below 0.56 were removed from the scale. Thus, the CVR values of the remaining items in the scale were in the range of 0.67-1.00, and the content validity index (CVI) value of the scale was calculated as 0.844, ensuring the content validity of the 15-item pilot scale.

**Pilot application:** After expert opinion was taken, a pilot-scale with 15 items was prepared on a 5-point Likert scale, which was determined to provide content validity. The e-survey method (Google Forms) applied the scale and descriptive information form to physicians working in the medical field in Turkey, who could give reliable answers to survey questions. The target number of physicians in the pilot application is to reach at least ten times the number of items on the scale (16). Physicians had to reply to the scale upon their own opinions.

### Statistical Analysis

Descriptive information of the groups (experts and physicians) was determined using descriptive and frequency analysis methods. To evaluate the content validity of the items in the scale, item CVR and scale CVI values were used. In estimating the psychometric properties of the scale, descriptive analyses of the scale, explanatory and confirmatory factor analysis for construct validity, Cronbach's

alpha analysis for reliability analysis were performed. Pearson correlation test and independent t-test were used in relationship and difference analysis. SPSS v23 package program and AMOS v24 statistics program were used for data analysis.

### RESULTS

A total of 292 physicians, 66.1% (n=193) male and 33.9% (n=99) female, participated in the study. The average age of the participants was  $35.0 \pm 8.2$  years. About 9.6% (n=28) of the physicians were general practitioners, 44.5% (n=130) were residents of various medical specialty programs and 45.9% (n=134) were specialist physicians. Of the physicians participating in the study 19.9% (n=58) reported receiving special training on athlete health and combating doping. The mean professional experience period of physicians was  $10.2 \pm 8.2$  years, and the rate of athletes among their patients was calculated as  $20.4 \pm 26.1\%$  (ranged 0 to 95%).

**Construct validity and reliability:** Item analysis was performed first to evaluate the scale's construct validity. According to the item analysis results, four items that created an increase in Cronbach's alpha coefficient. They were removed from the scale, as well as an item whose value was below 0.30 in the extraction column of the communalities table, during factor analysis.

The difference test (independent sample t-test), and item discrimination index values between the floor and ceiling 27% groups ( $p < 0.001$ ), in which the discrimination of the items in the scale was evaluated, were found to be appropriate. There was no floor (proportion of those with the lowest scores: 0.3%) and ceiling (proportion of those with the highest scores: 3.1%) effect on the scale.

Explanatory factor analysis was performed for construct validity of the scale. Basic components and the varimax rotation method were used for this. The suitability of the data and sample to be analyzed was determined by calculating the Kaiser-Meyer-Olkin (KMO) value as 0.784, Bartlett's Sphericity Test chi-square result was 1137, and the p-value was  $< 0.001$ . The factorability of each item was determined by the adequacy of the anti-image correlation value ( $> 0.05$ ) (the lowest: 0.731 and the highest: 0.875). In the explanatory factor analysis, all of the load distributions were found above 0.50, and the item quality was good (16).

It was observed that the scale items were gathered under two factors with an eigenvalue  $< 1$ . The factor's eigenvalues were 3.19 and 2.73, respectively, and the total variance rate explained was 59.3% (Figure 1).

The structure validity analysis results of the items remaining in the scale are presented in Table 1.

**Table 1.** Result of construct validity on items in the scale

Parameters	Subdimension 1: 'The practice of medicine'					Subdimension 2: 'Ethical approach'					
	It 2	It 3	It 4	It 5	It 6	It 7	It 9	It 10	It 11	It 13	
Mean	2.25	2.87	2.62	3.15	4.40	4.51	3.99	4.45	4.40	3.67	
Standard deviation	1.43	1.45	1.49	1.53	1.01	0.99	1.17	0.91	0.95	1.19	
Corrected item-TC	0.707	0.740	0.794	0.708	0.502	0.560	0.420	0.633	0.574	0.390	
Factor load	0.839	0.853	0.884	0.826	0.697	0.752	0.564	0.801	0.748	0.517	
It discrimination SI	9.098	16.87	16.36	20.02	6.424	6.368	9.430	7.124	6.684	9.446	
ANOVA-Tukey's p		0.348					0.325				
Hottelling's T-sq p		0.0001					0.0001				

It: item, TC: total correlation, SI: strength index, ANOVA-Tukey's p: ANOVA-Tukey's test for non-additivity p value, Hotelling's T-sq p: Hotelling's T-squared test p value

Cronbach's alpha reliability coefficient of the whole scale was calculated as 0.761. Considering the values presented in Table 2, the scale is highly reliable.

**Table 2.** Results regarding the reliability of the scale

Parameters	N of items	Cronbach Alfa	Conclusion
Subdimension 1: 'The practice of medicine'	4	0.878	High reliability
Subdimension 2: 'Ethical approach'	6	0.761	Reliability
Total scale	10	0.761	Reliability

Whether the explanatory structure of the scale was confirmed or not was examined by Confirmatory Factor Analysis (CFA). The adequacy of the model tested with CFA was determined by examining fit indices. Covariance was created between some items to increase the fit values. These results were accepted as indicating that the scale provided the confirmatory factor analysis fit values (Table 3, Figure 2).

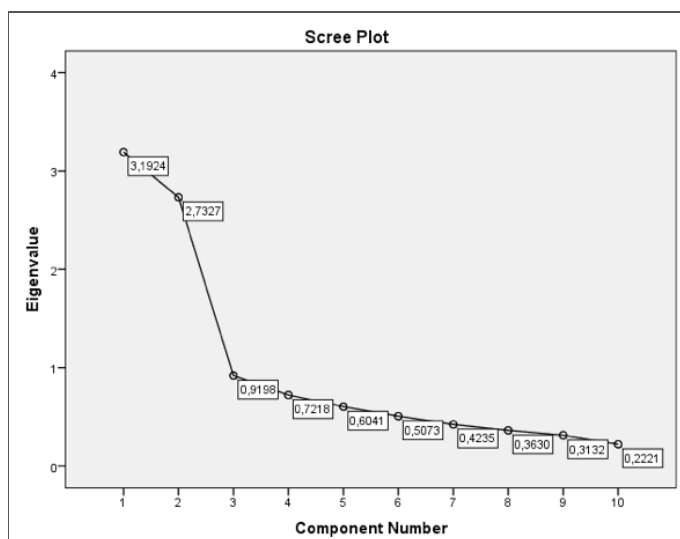

**Figure 1.** Scree plot graphic of the scale

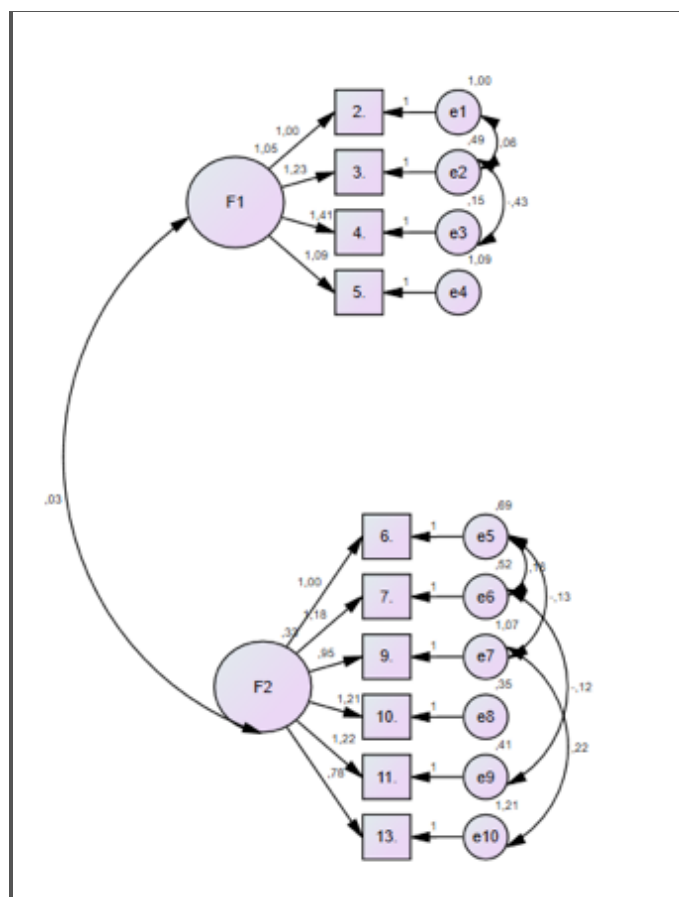

**Figure 2.** Confirmatory factor analysis diagram of the scale

The correlation and difference analysis of the independent variables at the scale scores were presented in the Table 4 & 5.

**Table 3.** Results of confirmatory factor analysis of the scale

Model fit indices	Value	Conclusion
Chi-square ( $\chi^2$ ) /degrees of freedom (df)	2.809	Good fit
Root Mean Square Error of Approximation (RMSEA)	0.079	Good fit
Standardized Root Mean Square Residual (SRMR)	0.131	Good fit
Comparative Fit Index (CFI)	0.954	Perfect fit
Goodness-Of-Fit Index (GFI)	0.951	Perfect fit
Adjusted Goodness-Of-Fit Index (AGFI)	0.905	Perfect fit
Incremental Fit Index (IFI)	0.955	Perfect fit
Turker-Lewis Index (TLI)	0.927	Good fit

**Table 4.** Relationship of independent variables on the scores

Parameter	Total Score	Subdimension 1 'The Practice of Medicine'	Subdimension 2 'Ethical Approach'
Total score	r value	1	
	p value		
Subdimension 1: 'The practice of medicine'	r value	<b>0.797**</b>	<b>0.693**</b>
	p value	0.0001	0.0001
Subdimension 2: 'Ethical approach'	r value	1	<b>0.118*</b>
	p value	0.0001	0.045
Age (yrs)	r value	<b>0.693**</b>	1
	p value	0.0001	0.045
Professional experience (yrs)	r value	<b>0.163**</b>	0.076
	p value	0.005	0.195
Rate of individuals practicing sports among patients(%)	r value	<b>0.133*</b>	0.069
	p value	0.023	0.237
	r value	<b>0.562**</b>	<b>0.181**</b>
	p value	0.0001	0.002

**Table 5.** Differences of independent variables on the scores

Groups	Total score	p	Subdimension 1	p	Subdimension 2	p
All participants	36.3±7.0	-	10.9±5.1	-	25.4±4.2	-
Gender						
Female(n=99)	37.1±5.7	0.119	11.2±4.6	0.372	25.9±3.9	0.183
Male(n=193)	35.9±7.5		10.7±5.33		25.2±4.4	
Special education athlete's health						
No(n=234)	34.4±5.8	<b>0.0001*</b>	9.4±4.1	<b>0.0001*</b>	25.0±4.4	<b>0.0001*</b>
Yes(n=58)	44.1±5.9		16.9±4.0		27.1±3.2	

Subdimension 1: 'The practice of medicine'; Subdimension 2: 'Ethical approach'

## DISCUSSION

The measurement tools like Performance Enhancement Attitude Scale (PEAS) (17), Doping Confrontation Efficacy Scale (DCES) (18), Moral Disengagement in Doping Scale (MDDS) (19), and Questionnaire of Attitudes towards Doping in Fitness (QAD-Fit) (20) can evaluate the attitude towards doping by athletes trainers or students, but not a physician. However, these measurement tools are designed for stakeholders like athletes, coaches, the general population, students, etc., who have a role in combating doping besides healthcare professionals. To the best of our knowledge, no measurement tool measuring physicians' attitudes towards doping exists in the literature yet. However, it is essential to evaluate the attitudes of health professionals towards doping to protect the health of athletes and manage the fight against doping effectively. According to the data obtained at the end of this survey, 'Attitudes of Physicians Against Doping' has been a reliable and valid measurement tool to determine attitudes towards doping of physicians practicing in Turkey (Appendix).

This study followed the methodological steps suggested in the literature (16), and was started by creating an item pool consisting of 47 items. The item pool was reduced to 15 items providing content validity after the expert opinion stage, and ten items with validity and reliability after the pilot application. During the development of the Performance Enhancement Attitude Scale (PEAS) (17), the 97-item pool decreased to 17 items, in the Doping Confrontation Efficacy Scale (DCES) (18) the 64-item pool decreased to 21 items, in the Moral Disengagement in Doping Scale (MDDS) (19) the 12-item pool decreased to 6 items, in the Questionnaire of Attitudes towards Doping in Fitness (QAD-Fit) (20), the 34-item pool decreased to 16 items. This course observed in our study was also observed and expected in other scale development studies.

In the pilot application phase of the scale development studies, it is recommended to reach 5-20 times the number of variables, thus

reaching the appropriate sample size for the validity and reliability analysis of the scale (16). As in other studies (18,20,21), the ideal sample size was achieved by including at least ten times the number of items in our study.

The factor analysis of the scale we developed determined that the item quality was at a reasonable level, with loads of the items above 0.50. Cronbach's alpha coefficient of the scale was calculated as 0.761, and this result was accepted as an indicator of the high level of reliability of the scale. Similarly, the factor loads of the Questionnaire of Attitudes towards Doping in Fitness (QAD-Fit) (20) remained above 0.60. The Cronbach's alpha coefficient of Performance Enhancement Attitude Scale (PEAS) (17) was found to be between 0.71-0.91 in different sample groups, and 0.78 for Moral Disengagement in Doping Scale (MDDS) (19). As can be seen, the validity and reliability level of the scale we developed was compatible with the values suggested in the literature. Also, the adequacy of the scale (16) was determined by calculating the variance rate explained in our scale as 59.3%.

The goodness of fit index is vital in confirmatory factor analysis since it is an evaluation in which the model included in the explanatory factor analysis is tested. In the analysis of the scales that examine attitude towards doping fit indices such as;  $c^2 /sd$ , root mean square error of approximation (RMSEA), standardized root mean square residual (SRMR), comparative fit index (CFI), Tucker-Lewis index (TLI), etc. (17-21). A perfect fit is accepted as the RMSEA and SRMR values are in the range of 0-0.05, the CFI, GFI, IFI and TLI values are in the range of 0.95-1.00, and the AGFI value in the range of 0.90-1.00, when " $c^2 /sd$ " value in the fit indices is in the range of 0-2 (22). When confirmatory factor analysis fit values of the scale we developed are examined, it is seen that the scale meets the recommended values for the good-perfect fit.

As to the limitations of the study; it could not be evaluated whether the physicians included in the study inadvertently or intentionally helped athletes use the active substance or medical method in the “prohibited List”. Thus, it could not be evaluated whether there was a difference between the knowledge and attitude of the physicians. This situation constitutes the limitation of our research.

## CONCLUSION

"Physicians' Attitude Scale towards Doping" has been developed, in which the attitudes of physicians, who have an essential role in combating doping, can be evaluated. The validity and reliability of the single-factor scale with four items were provided and introduced into the literature.

### Acknowledgement

We would like to thank all academicians who shared their expert opinions and physicians who have participated in our research.

### Ethics Committee Approval / Etik Komite Onayı

The approval for this study was obtained from Süleyman Demirel University Ethics Committee (Decision no: 102 Date: 17.02.2021).

### Conflict of Interest / Çıkar Çatışması

The authors declared no conflicts of interest with respect to authorship and/or publication of the article.

### Financial Disclosure / Finansal Destek

The authors received no financial support for the research and/or publication of this article.

### Author Contributions / Yazar Katkıları

Concept all authors; Design all authors; Supervision all authors; Materials all authors; Data Collection and/or Processing all authors; Analysis and Interpretation all authors; Literature Review all authors; Writing Manuscript all authors; Critical Reviews all authors.

## REFERENCES

1. TDMK. Türkiye dopingle mücadele talimatı. [cited 2021 July 1]; <https://www.tdmk.org.tr/wp-content/uploads/2016/03/Türkiye-dopingle-mücadele-talimatı-2021.pdf>
2. Domagala-Rodacka R, Rodacki T, Owczarek D, Cibor D, Zagrodzki P. Doping in sport - attitude and professional experience among physicians in Poland. *Folia Med Cracov.* 2018;58(3):35-47.
3. Brun SP. Some current challenges facing the athlete and their doctor. *Aust J Gen Pract.* 2020;49(1-2):23-31.
4. Tandon S, Bowers LD, Fedoruk MN. Treating the elite athlete: anti-doping information for the health professional. *Mo Med.* 2015;112(2):122-8.
5. Vernec AR. Doping, ethics, and the sport physician. *Curr Sports Med Rep.* 2013;12(5):283-4.
6. Ekmekci PE. Physicians' ethical dilemmas in the context of anti-doping practices. *Ann Sports Med Res.* 2016;3(7):1089.
7. Ozkan O, Torgutalp SS, Kara OS, Donmez G, Demirel H, Karanfil Y, et al. Doping knowledge and attitudes of Turkish athletes: a cross-sectional study. *Monten J Sports Sci Med.* 2020;9(1):49-55.
8. Di Luigi L, Pigozzi F, Sgrò P, Frati L, Di Gianfrancesco A, Cappa M. The use of prohibited substances for therapeutic reasons in athletes affected by endocrine diseases and disorders: the therapeutic use exemption (TUE) in clinical endocrinology. *J Endocrinol Invest.* 2020;43(5):563-73.
9. WADA. TUE. [cited 2021 July 1]. [https://www.wada-ama.org/sites/default/files/resources/files/international\\_standard\\_is-tue\\_-\\_2021.pdf](https://www.wada-ama.org/sites/default/files/resources/files/international_standard_is-tue_-_2021.pdf)
10. Laure P, Binsinger C, Lecerf T, Ayotte C. General practitioners and doping in sport: attitudes and experience. *Br J Sports Med.* 2003;37(4):335-8.
11. Ercan S, Oğul A, Canbulut A, Arslan E, Çetin C. Knowledge and attitudes of intern physicians on nutritional ergogenic supplementation and doping. *Türk J Sports Med.* 2021;56(2):61-6.
12. Pope HG, Kanayama G, Ionescu-Pioggia M, Hudson JL. Anabolic steroid users' attitudes towards physicians. *Addiction.* 2004;99(9):1189-94.
13. Greenway P, Greenway M. General practitioner knowledge of prohibited substances in sport. *Br J Sports Med.* 1997;31(2):129-31.
14. Woods CB, Moynihan A. General practitioners knowledge, practice and training requirements in relation to doping in sport. *Ir Med J.* 2009;102(1):8-10.
15. Rashid H, Ormerod S, Day E. Anabolic androgenic steroids: what the psychiatrist needs to know. *Adv Psychiatr Treat.* 2007;13(3):203-11.
16. Alpar R. *Spor Sağlık ve Eğitim Bilimlerinden Örneklerle Uygulamalı İstatistik ve Geçerlik Güvenirlik*. 6. baskı. Ankara: Detay Anatolia Akademik Yayıncılık; 2020.
17. Petróczy A, Aidman E. Measuring explicit attitude toward doping: review of the psychometric properties of the Performance Enhancement Attitude Scale. *Psychol Sport Exerc.* 2009;10(3):390-6.
18. Sullivan PJ, Feltz DL, LaForge-MacKenzie K, Hwang S. The preliminary development and validation of the Doping Confrontation Efficacy Scale. *Psychol Sport Exerc.* 2015;16:182-90.
19. Kavussanu M, Hatzigeorgiadis A, Elbe AM, Ring C. The moral disengagement in doping scale. *Psychol Sport Exerc.* 2016;24:188-98.
20. Tavares ASR, Serpa SO, Boleto Rosado AF. Psychometric properties of the questionnaire of attitudes towards doping in fitness (QAD-Fit). *Motriz Rev Educ Fís.* 2019;25(2):e101925.
21. Nicholls AR, Madigan DJ, Levy AR. A confirmatory factor analysis of the performance enhancement attitude scale for adult and adolescent athletes. *Psychol Sport Exerc.* 2017;28:100-4.
22. Özdamar K. *Eğitim, Sağlık ve Davranış Bilimlerinde Ölçek ve Test Geliştirme Yapısal Eşitlik Modellemesi*. Eskişehir: Nisan Kitabevi; 2016.

## Appendix. Physicians' Attitude Scale Towards Doping

## 'Hekimlerde Dopinge Yönelik Tutum Ölçeği'

Aşağıdaki önermeleri, '1. Kesinlikle katılmıyorum, 2. Katılmıyorum, 3. Kararsızım, 4. Katılıyorum ve 5. Kesinlikle katılıyorum' seçeneklerinden size göre en doğru olanı işaretleyerek cevaplayınız.

	1. Kesinlikle katılmıyorum	2. Katılmıyorum	3. Kararsızım	4. Katılıyorum	5. Kesinlikle katılıyorum
1					
2					
3					
4					
5					
6					
7					
8					
9					
10					

**Açıklama:** Ölçek, iki faktör altında toplanan 10 maddeden oluşmaktadır. Ölçekteki 1.-4. maddeler, ölçeğin 'hekimlik pratiği' alt boyutunu; 5.-10. maddeler 'etik yaklaşım' alt boyutunu oluşturmaktadır. Maddelere verilen cevaplar toplanarak ölçek alt boyut puanlarına ve ölçek toplam puanına ulaşılmaktadır. Ölçeğin 'hekimlik pratiği' alt boyutundan en az 4 ve en fazla 20 puan; 'etik yaklaşım' alt boyutundan en az 6 ve en fazla 30 puan; ölçeğin tamamından en az 10 puan ve en fazla 50 puan alınabilmektedir. Ölçekten alınan puanın artması doping ile mücadele yönünde tutum gösterildiğini ifade etmektedir.