







# Adaptation of the Decision to Forgive Scale to Turkish Culture: Validity and Reliability Study\*

Gülbin DEMİR CELAYİR<sup>1</sup>, Ece YAĞCI AKGÜNDÜZ<sup>2</sup>, Simel PARLAK<sup>3</sup>, Halil EKŞİ<sup>4</sup>

<sup>1</sup>Ministry of National Education, İstanbul, Türkiye  0000-0002-5284-3320

<sup>2</sup>Istanbul Sabahattin Zaim University, Faculty of Education, İstanbul, Türkiye  0000-0002-2765-1773

<sup>3</sup>Istanbul Sabahattin Zaim University, Faculty of Education, İstanbul, Türkiye  0000-0002-8651-2693

<sup>4</sup>Marmara University, Faculty of Education, İstanbul, Türkiye  0000-0001-7520-4559

## ARTICLE INFO

Article History  
Received Click  
Received in revised form  
Click  
Accepted Click  
Article Type: Research  
Article



## ABSTRACT

This study aims to adapt the Decision to Forgive Scale, initially developed by Davis et al. (2015), for use in Turkish culture. The focus is on evaluating the scale's validity and reliability within the Turkish context, providing researchers and counselors with a tool to measure the decision to forgive, separate from the act of forgiveness itself. The adaptation process involved linguistic equivalence studies, where five bilingual individuals translated the scale into Turkish. The translated version was then back-translated into English for comparison. Confirmatory Factor Analysis (CFA) was conducted with data from 297 participants to assess the construct validity of the scale. Criterion validity was evaluated through correlation with the Heartland Forgiveness Scale's Forgiveness of Others subscale (HFS-FO). Reliability was tested using Cronbach's alpha. The CFA results confirmed that the Turkish version of the Decision to Forgive Scale has a one-dimensional structure with high model fit indices (e.g., RMSEA = .08, CFI = .99). The scale demonstrated high internal consistency with a Cronbach's alpha of .91. Criterion validity analysis showed a significant positive correlation ( $r = .527$ ) with the HFS-FO. The Turkish adaptation of the Decision to Forgive Scale is valid and reliable. This scale can effectively measure the decision to forgive among Turkish individuals, offering a valuable tool for both research and therapeutic settings. It can help understand and enhance forgiveness-related processes and interventions in Turkish culture.

Keywords:

Decision to forgive, scale adaptation, psychometric properties, Turkish culture

## 1. Introduction

Forgiveness is gaining prominence in the disciplines of psychology and positive psychology. As the growing number of studies on this topic further delineates the positive effects of forgiveness on quality of life, psychological well-being, and interpersonal relationships (Worthington et al., 2020), it becomes evident that this concept is an essential tool in applied psychology that helps individuals overcome psychological problems (Hook et al., 2009). Moreover, individuals who experiencing guilt or shame may find self-forgiveness helpful in alleviating these negative emotions and improving their overall mental health and well-being (Cornish et al., 2017). In addition, forgiveness interventions have been related with various outcomes, for example greater mental health and a lower risk of depression (Lin et al., 2004; Svalina & Webb, 2012). In this context, forgiveness can be seen as an effective strategy that enhances psychological well-being by strengthening individuals' relationships with themselves and others.

\*Corresponding author's address: Istanbul Sabahattin Zaim University, Türkiye

e-mail: [eceyagci8@gmail.com](mailto:eceyagci8@gmail.com)

**Citation:** Demir Celayir, G., Yağcı Akgündüz, E., Parlak, S., & Ekşi H. (2024). Adaptation of the decision to forgive scale to Turkish culture: Validity and reliability study. *International Journal of Psychology and Educational Studies*, 11(4), 331-341.

<https://dx.doi.org/10.52380/ijpes.2024.11.4.1371>

Additionally, forgiveness has been associated with enhanced physical health, reduced pain, and more effective drug relapse management (Lin et al., 2004; Svalina & Webb, 2012). These studies, which all emphasize the profound impact of forgiveness on psychological health and human relationships, demonstrate that forgiveness can improve individuals' inner worlds and can also serve as a factor that strengthens social and cultural structures (McCullough et al., 2000). This broad spectrum of forgiveness continues to be a topic of interest in disciplines as diverse as psychology, sociology, educational sciences, and even business.

Forgiveness starts when people sincerely declare their intention to reduce unfavorable interactions in ongoing relationships and take constructive steps to preserve close relationships (Duggi & Kamble, 2014). This process usually starts with a deliberate choice influenced by the person's interpretation of the hostile experience and their desire to handle relationship dynamics going forward (Fourie et al., 2020). Erigh (2019) states that forgiveness is a choice. According to Prochaska and DiClemente (1982), the Transtheoretical Model of Change suggests that clients may begin therapy at varying motivational stages concerning forgiveness. These stages include complete opposition, openness to the idea of forgiveness, readiness to forgive, actively seeking solutions, and complete success in forgiving (Prochaska & DiClemente, 1982). Forgiveness therapies support this process with an affirming approach, encouraging clients to decide to forgive or express their complex emotions regarding this decision (Davis et al., 2015). If we consider the realization of forgiveness in forgiveness therapies as an outcome that improves individuals' well-being, deciding to forgive is the first step towards this goal.

Worthington, et al. (2007) highlight the distinction between individuals' decision to forgive and forgiveness per se. This distinction is frequently discussed in theoretical and empirical forgiveness research (Lichtenfeld et al., 2015; Lichtenfeld et al., 2019; Wade et al., 2014). There is a large body of research that treats the decision to forgive as a separate construct from emotional forgiveness (see Byra, 2024; Chen et al., 2023; Cook et al., 2022; Perez, 2023; Skalski-Bednarz, 2024). For example, Cook, et al. (2022) found that the decision to forgive had more positive and consistent effects on people's well-being in the short term than emotional forgiveness, whereas emotional forgiveness only improved interpersonal relationships. In another study, Chen et al. (2023) measured Muslims' levels of emotional forgiveness and decision to forgive during Ramadan and concluded that emotional forgiveness and decision to forgive are affected by each other. Worthington et al (2007) stated that choosing to forgive is a crucial step toward developing a forgiving disposition, leading to positive emotional changes. Davis et al. (2015) created a measurement tool specifically for the decision to forgive. This scale created to separate the decision to forgive from the act of forgiveness, and significantly enhances the understanding of the complexity and multidimensional structure of the forgiveness. This emphasizes the importance of having separate tools to accurately measure these related but distinct concepts.

Various scales related to the concept of forgiveness have been adapted into Turkish (Aydın & Yerin Güneri, 2017; Havare & Gizir, 2020) or developed in Turkey (Ersanlı & Vural-Batık, 2015; Kaya, 2019). However, no scale distinguishes the decision to forgive from forgiveness itself and has been adapted to Turkish culture. For this reason, it is thought that the Decision to Forgive Scale (DTFS) (Davis et al., 2015), which is aimed to be translated into Turkish in this study and to calculate its psychometric properties, will enable further research to examine the effects of the decision to forgive on various structures such as psychological well-being, relationship dynamics, and mental health in Turkish culture. In addition, it can be used in experimental research to help understand how individuals' decision to forgive is related to emotional and cognitive processes. Finally, the adapted scale will contribute to understanding the universal and culturally specific dynamics of forgiveness by providing an opportunity to examine how the decision to forgive varies across different cultures. In this way, it will provide a tool for researchers and counselors in Turkey to evaluate and improve the effectiveness of therapeutic interventions related to forgiveness. In this context, the current study aims to assess the validity and reliability of the DTFS developed by Davis et al. (2015) in the Turkish context.

## **2. Methodology**

### **2.1. Adaptation Process**

The DTFS was adapted into Turkish in the present study, and its psychometric properties were calculated. Initially, the author responsible for developing the original scale was contacted, and the necessary permissions for its use were obtained. Subsequently, five individuals who were proficient in both English and Turkish translated the scale into Turkish as part of the linguistic equivalence studies. Then, the researchers analyzed

the translations, and the Turkish scale was created. An English teacher translated the scale from Turkish back into English. The researchers finalized the scale by comparing the original English form, the Turkish form and the English forms created after back translation.

The construct and criterion validity analyses were conducted as part of the validity studies of the Turkish DTFS. In the development of the original scale (Thomson, 2015) and in studies conducted in different cultures (Mróz, 2022; Recoder, 2019), the validity and reliability of the scale were tested with large samples, exploratory and confirmatory factor analyses were conducted, and it was determined that it showed a single-factor structure. Confirmatory Factor Analysis (CFA) is a type of analysis used to test whether the structure of a scale, based on a predetermined model, fits the current data (Tabachnick and Fidell, 2013). The exploratory nature of Exploratory Factor Analysis (EFA) is not intended to fulfill the need to confirm an already established construct, but to reveal the construct (Kline, 2015). For these reasons, CFA rather than EFA was preferred to determine the construct validity of the scale. In other words, CFA was conducted to determine whether the factor structure of the adapted scale was compatible with the original scale. In this study, a CFA was conducted with the data obtained from 297 individuals who participated in the study voluntarily. In the context of validity studies, the correlation values between the data obtained from the DTFS translated into Turkish and the Heartland Forgiveness Scale Forgiveness of Others Subdimension (HFS-FO) were examined in order to determine criterion validity. Finally, item analyses were conducted, and the Cronbach alpha value was then calculated.

## 2.2. Research Sample

The data of the current research were collected through convenience sampling. Convenient sampling involves selecting participants who are readily available and willing to take part in the research (Fraenkel et al., 2011). The convenience sampling method used in this study to prevent limitations that may occur in terms of time. The data were collected from 297 adults who were reached through convenience sampling and volunteered. Online and printed forms were used together in the data collection process. Studies have shown no significant quantitative and qualitative differences between online and paper forms (Weigold, et al., 2013; Ward, et al., 2014).

## 2.3. Data Collection Tools and Procedure

*Decision to Forgive Scale:* The DTFS was developed by Davis et al. (2015), aiming to differentiate the forgiveness decision from actual forgiveness levels in the individual. The Scale was applied to 432 adults in the United States: 298 females and 134 males. It is a one-factor scale with six items. The minimum score obtained from the Scale is 6, and the maximum is 30. The scale utilizes a 5-point Likert format, where responses range from 1 (Strongly Disagree) to 5 (Strongly Agree). There are no reverse-scored items on the scale. Higher scores reflect a stronger tendency to forgiveness decision. The factor structure of the scale items was examined by confirmatory factor analysis (CFA) and it was found that the one-factor structure of the scale was confirmed. As part of the validity studies of the DTFS, discriminant validity was achieved by examining the scale's relationship with the Transgression-Related Interpersonal Motivations Scale (TRIM) (McCullough et al., 1998). In the second study, the consistency of the DTFS over time and its relationship with other related constructs were examined; in this study, it was found that the scale yielded reliable results over time (Davis et al., 2015). Reliability studies were conducted by analyzing Cronbach's alpha coefficients and test-retest reliability, and it was determined that the scale showed high internal consistency ( $\alpha = .92 - .94$ ) and consistency over time (1-week test-retest correlation = .68) (Davis et al., 2015). In the current study, the reliability of the scale was determined using Cronbach's Alpha and a value of .91 was obtained. This shows that the scale is a reliable measurement tool.

*Heartland Forgiveness Scale:* Originally developed by Thompson et al. (2005), the Heartland Forgiveness Scale was subsequently translated and adapted into Turkish by Bugay and Demir (2010), who also evaluated its psychometric characteristics. It comprises three sub-dimensions: "self-forgiveness", "forgiveness of others", and "forgiveness of the situation". Each sub-dimension comprises six items. Higher scores indicate a higher level of forgiveness. Validity assessment of the original Heartland Forgiveness Scale (HFS) included conducting both exploratory factor analysis (EFA) and confirmatory factor analysis (CFA) to confirm construct validity, resulting in good model fit (CFI = .936, RMSEA = .053). Furthermore, convergent and discriminant validity tests indicated that the HFS had significant correlations with other forgiveness scales and related constructs and retained low correlations with social desirability bias. Within the scope of Turkish adaptation

studies, validity results showed a good fit for the Turkish sample (CFI = .90, RMSEA = .06). The Cronbach's alpha value of the scale adapted to Turkish was calculated as .81 for the overall scale, .64 for the "self-forgiveness" subscale, .79 for "forgiveness of others", and .76 for the "forgiveness of situation" subscale (Bugay & Demir, 2010). In order to evaluate the criterion validity of the current study, the scores obtained from the "Forgiveness of Others" (HFS-FO) subscale of the scale were utilized. The Cronbach's Alpha reliability coefficient of the HFS-FO calculated in this study was .73.

#### 2.4. Ethical

This paper is an extended and revised version presented by Ekşi, H., Parlak, S., and Demir-Celayir, G. (May 2018) titled "Adaptation of the DTFS into Turkish." The paper was presented at the 1st International Congress on New Trends in Education, Istanbul. Ethical approval from an ethics committee was not required since the data were collected during the 2017-2018 academic year. However, all participants were thoroughly informed about the nature of the study both in writing and orally. Their consent to participate was obtained prior to their involvement in the research.

### 3. Findings

#### 3.1. Construct Validity

An analysis of the descriptive statistics for the scale items revealed that the mean values ranged from 0.72 to 2.97, and the standard deviations varied from 1.07 to 1.47. The skewness and kurtosis values were within the range of -2 to +2. These values indicate the assumption of normality, one of the assumptions of the Confirmatory Factor Analysis (CFA), is met (George & Mallery, 2019). Before applying the CFA, outlier analyses were conducted, and no outliers were identified. Another assumption of the CFA, which is having a sample size at least ten times the number of items (Nunnally, 1978), was also met (N=297).

Upon completing the CFA, the chi-square value and various indices for assessing model fit were reviewed (Byrne, 2010; Hu & Bentler, 1999; Kline, 2015). These indices included the Root Mean Square Error of Approximation (RMSEA), Goodness of Fit Index (GFI), Adjusted Goodness of Fit Index (AGFI), Comparative Fit Index (CFI), Tucker-Lewis Index (TLI), and Standardized Root Mean Square Residual (SRMR). The fit indices and model values derived from the CFA, which were used to evaluate the construct validity of the DTFS, are displayed in Table 1. Figure 1 depicts the scale's one-dimensional structure and the factor loadings of the items for the Turkish sample.

**Table 1** Fit Indices and Model Values Obtained as a Result of CFA

Fit Index	Model Value
$\chi^2/sd$ (CMIN/df)	3.23
RMSEA	.08
GFI	.97
AGFI	.92
CFI	.99
TLI	.97
SRMR	.02

As illustrated in Figure 1, the items' factor loadings range from 0.60 to 0.92. As outlined by Byrne (2010), when high modification indices are identified, modifications between the error terms of the items can be drawn if the changes made among the items are theoretically reasonable. The modifications statistically improve the overall model fit. In the initial stage of CFA, based on the observed modification indices and theoretical review, modifications were sequentially drawn between the fixed errors of the items, as observed in Figure 1. The obtained values suggest that the Turkish form of the inventory can be considered to have "perfect fit" or "acceptable fit" model values in terms of fit indices (Byrne, 2010; Hu & Bentler, 1999; Kline, 2015).

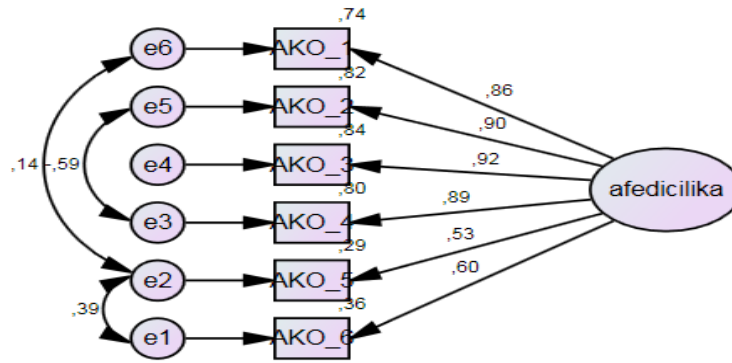

**Figure 1** Path Diagram for the Decision to Forgive Scale and Factor Loadings

### 3.2. Criterion Validity

The criterion validity of the DTFS was assessed using the HFS-FO (Bugay & Demir, 2010; Thompson et al., 2005). The criterion validity was tested using Pearson Product-Moment Correlation Analysis. The HFS-FO and the DTFS scores exhibited a statistically significant positive correlation ( $r = 0.527$ ).

**Table 2** Criterion Validity Analysis Findings

	N	X	Sd	R
The DTFS	297	19.16	5.64	
Heartland Forgiveness Scale Forgiveness of Others Sub- Dimension	297	25.94	7.02	.527*

\* $p < .01$

### 3.3 Reliability

The item analysis was carried out as part of the reliability studies. The results of the item analysis are presented in Table 3. The corrected item-total correlation values for the items of the DTFS range from .59 to .84, indicating that the items are consistent with the Scale and exhibit high internal consistency. The correlation coefficients demonstrate that the items are strongly related to the overall concept of the decision to forgive. Additionally, the findings related to the t-test results indicate that the Scale identifies significant differences between the lower and upper 27% groups. Based on these findings, it is evident that the Scale can distinguish the concept of the decision to forgive among individuals at different levels.

**Table 3** Adjusted Item Total Correlations and Findings on t-Test Results

Scale	Item	Adjusted Item-Total Correlation	Findings on t-Test Results
The DTFS	1	.82	-23,16*
	2	.78	-24,17*
	3	.84	-33,78*
	4	.82	-22,97*
	5	.59	-11,50*
	6	.63	-16,06*

27% N=297 in Over-Under "t" test analysis, For 27%,  $n_1=n_2=80$ , \* $p < .001$

Finally, based on the collected data, the reliability analyses revealed a Cronbach's alpha internal consistency coefficient of .91 for the scale's single-factor structure. This high coefficient indicates strong internal consistency. Therefore, the findings suggest that the Turkish adaptation of the DTFS is both a valid and reliable tool for measurement.

## 4. Discussion, Conclusion and Recommendations

This study aimed to adapt the DTFS (Davis et al., 2015), for use in Turkish culture and to evaluate its psychometric properties. Within this framework, linguistic, construct, criterion-related validity, internal consistency, and item analyses were conducted. As part of the linguistic validity studies, five individuals who

were proficient in both English and Turkish translated the original scale into Turkish. The researchers then reviewed the translations. Thus, the Turkish form of the scale was produced. An English teacher back-translated the scale from Turkish into English. The researchers compared the original, Turkish, and back-translated English forms to finalize the scale.

CFA was conducted on 297 adults to test the scale's construct validity. All the fit scores associated with the model obtained are excellent or within the acceptable range. As a result of the analysis, the unidimensional and 6-item structure of the inventory was confirmed for Turkish culture. Internal consistency and item analyses were conducted within the scope of tests related to the scale being a reliable measurement tool. Cronbach alpha value was analyzed to examine internal consistency. As a result, the scale demonstrated a Cronbach's alpha coefficient of .91. In the original research conducted by Davis et al. (2015), Cronbach's alpha values were reported as .93, .92, and .94 across three different measurements. The item analysis conducted within the scope of reliability analyses revealed that the items were compatible with the scale and showed high internal consistency. Correlation coefficients show that the items of the scale have a strong relationship with the general concept of the decision to forgive. In addition, t-test results show that the scale detected significant differences between the lower and upper 27 percentile groups. The scale adopted in the present study has the ability to distinguish the concept of the decision to forgive among individuals at different levels.

The HFS-FO (Bugay & Demir, 2010; Thompson et al., 2005) was used for criterion-related validity analyses. The criterion validity was assessed using Pearson product-moment correlation analysis. The analysis revealed a statistically significant positive relationship between the DTFS scores and the HFS-FO scores ( $r = .527$ ).

The findings suggest that the scale is both reliable and valid, demonstrating that the items accurately measure the intended concept. The high corrected item-total correlations confirm that the scale has a cohesive structure and that the items are consistent with each other. Additionally, the t-test results reveal that the items possess high discriminative power. Overall, these results indicate that the scale has robust psychometric properties, making it suitable for use in both research and applied settings.

In the mental health field, for example, forgiveness-focused interventions and techniques are being developed in group therapy (Rainey et al., 1993), family therapy (Ripley & Worthington, 2002), individual therapy, and mental health interventions in older adulthood (Allemand, 2008), and their positive effects on therapeutic outcomes have been reported (Enright & Fitzgibbons, 2015; Enright et al., 2016; Enright, et al., 2020; Sandage et al., 2003). Research consistently shows that forgiveness is positively associated with posttraumatic growth (Byra et al., 2022; Gilo et al., 2020; Ha et al., 2019; Ye et al., 2022). Forgiveness not only directly increases posttraumatic growth but also does so indirectly through mechanisms such as social support, reduction of negative emotions, and meaning-making (Kararmak & Güloğlu, 2014; Lee & Kim, 2021; Ye et al., 2022). Forgiveness is essential for someone to recover from traumatic experiences and repair their relationships (Enright & Fitzgibbons, 2015; Murray, 2002). In this context, considering the therapeutic effects of the concept of forgiveness, individuals' decision to forgive can support individuals in reducing the impact of traumatic experiences, accelerate their healing processes, and help them establish healthier interactions by reducing conflicts in their relationships.

Research on forgiveness has shown that emotional and decisional forgiveness are separate constructs and should be addressed separately (Lichtenfeld et al., 2015; Lichtenfeld et al., 2019). Distinguishing forgiveness decision-making from emotional forgiveness is vital for understanding the multifaceted nature of forgiveness. Emotional forgiveness, characterized by replacing negative emotions with positive ones, facilitates psychological distancing from the offense and supports intentional forgetting. This process differs from the decision to forgive, which is related more to behavioral intentions (Noreen & Macleod, 2020; Worthington et al., 2007). Choosing to forgive is a crucial phase in the forgiveness process and has important implications for other forgiving motivations (Gamiz et al., 2022). Research indicates that the decision to forgive is associated with several psychological outcomes, including lower levels of anger, anxiety, and depression, as well as higher life satisfaction (Wang et al., 2022). Wu et al. (2022) noted that the decision to forgive affects emotional forgiveness. The forgiveness decision may play an essential role in the beginning of the forgiveness process and may influence individuals' emotional healing processes. Researchers can explore how the decision to forgive differs from emotional forgiveness in Turkish culture and how it affects psychological and relationship-based outcomes by using the DTFS, adapted in the current study (Davis et al., 2015).

The decision to forgive is a complex psychological process influenced by several elements, including apology, personality traits, contextual variables, and the perceived benefits and costs of forgiveness (Worthington et al., 2007). Understanding these factors can help develop interventions and models to facilitate forgiveness in different contexts. The Decision to Forgive Scale allows us to investigate the impact of the decision to forgive on mental health in Turkish culture. Furthermore, The Decision to Forgive Scale can be integrated into clinical settings to assess the effectiveness of individual and couple interventions based on forgiveness. Thus, this scale can help clinicians and researchers understand the role of the forgiveness decision in individual and family/couple therapy processes (Baskin & Enright, 2004).

The Decision to Forgive Scale is a measure that has been researched for validity and reliability in different cultural contexts and has applicability in various populations (Davis et al., 2015; Ikedo et al., 2020). Researchers can use the Scale to compare forgiveness processes across cultures or to examine how cultural factors influence the decision to forgive. Therefore, the scale provides a means of understanding the complexity of forgiveness across cultures, making it a valuable tool for intercultural studies. Additionally, the Decision to Forgive Scale may also assist practitioners in developing forgiveness-based, culturally sensitive interventions. Although, the missing demographic information of the participants is one of the important limitations of this study. The fact that demographic information was not recorded or incompletely recorded during the data collection process may limit the generalizability of the study. This may create difficulties in assessing the applicability of the findings of the current study to different demographic groups. In future studies, more attention should be paid to the complete collection of demographic data. In addition, this limitation of the study should be taken into consideration when developing intervention programs for the decision to forgive.

Convenience sampling was used to conduct the current research on a limited number of samples. Although validity and reliability analyses have been conducted, verifying these findings with additional studies on more extensive and diverse samples is useful. For example, a broader sample size, including those recently betrayed, could be used to replicate the study. In addition, the time elapsed since the data collection is one of the limitations of this study. Collecting the data in more recent and larger samples will contribute to the validity and reliability of the scale. The lack of test-retest reliability is one of the limitations of this study. However, Chen et al. (2023) in their study conducted in a Muslim sample in Pakistan measured 6 times and found that the Decision Making Forgiveness Scale provided consistent and reliable measurements over time. This finding shows that the scale can provide consistent results in non-Western cultures. Nevertheless, the consistency of the scale over time can be tested in Turkish culture in future studies. Both paper and online questionnaires were used in the data collection process, and it is essential to consider the possible effects of this approach on participants' responses. In addition, the criterion validity of the study was assessed using only one unambiguous scale. Future research could measure related constructs using multiple scales to increase the scale's validity.

## 5. References

- Allemand, M. (2008). Age differences in forgiveness: The role of future time perspective. *Journal of Research in Personality*, 42(3), 1137–1147. <https://doi.org/10.1016/j.jrp.2008.02.009>
- Aydın, G., & Yerin-Güneri, O. (2017). *Testing factor structure and reliability of the Turkish version of State Self-Forgiveness Scale (SSFS)*. EJER 4th International Eurasian Educational Research Congress. Denizli, Turkey.
- Baskin, T., & Enright, R. (2004). Intervention studies on forgiveness: A meta-analysis. *Journal of Counseling and Development*, 82, 79–90. <https://doi.org/10.1002/J.1556-6678.2004.TB00288.X>
- Bugay, A., & Demir, A. (2010). A Turkish version of heartland forgiveness scale. *Procedia Social and Behavioral Sciences*, 5, 1927-1931. <https://doi.org/10.1016/j.sbspro.2010.07.390>
- Byra, S., Kaleta, K., & Mróz, J. (2022). Posttraumatic growth and interpersonal forgiveness in persons with physical disabilities. *Rehabilitation Psychology*, 67(4), 567. <https://doi.org/10.1037/rep0000451>
- Byra, S. (2024). Forgiveness and well-being in mothers of children with disabilities. *Journal of Pediatric Nursing*, 77, e531-e537. <https://doi.org/10.1016/j.pedn.2024.01.003> b

- Byrne, B. M. (2010). *Structural equation modeling with AMOS: Basic concepts, applications, and programming (2nd ed.)*. Routledge.
- Chen, Z. J., Cowden, R. G., Ross, J. R., Harris, K., & Worthington, E. L. (2023). Can emotional forgiveness promote a decision to forgive? Evidence from a six-wave random-intercept cross-lagged panel study of Pakistani Muslims during Ramadan. *Journal of Positive Psychology, 18*(1), 123-135. <https://doi.org/10.1080/17439760.2023.2257679>
- Cook, K. V., Kurniati, N. M. T., Suwartono, C., Widyarini, N., Worthington, E. L. Jr., & Cowden, R. G. (2022). Differential effects of decisional and emotional forgiveness on distress and well-being: A three-wave study of Indonesian adults. *Frontiers in Psychology, 13*, 918045. <https://doi.org/10.3389/fpsyg.2022.918045>
- Cornish, M.A., Wade, N.G., Cikara, A. (2017). Self-forgiveness in individual psychotherapy: Therapeutic models and counseling outcomes. In Woodyatt, L., Worthington, Jr., E., Wenzel, M., Griffin, B. (eds) *Handbook of the psychology of self-forgiveness*. Cham. [https://doi.org/10.1007/978-3-319-60573-9\\_12](https://doi.org/10.1007/978-3-319-60573-9_12)
- Davis, D., Hook, J., Tongeren, D., DeBlare, C., Rice, K., & Worthington, E. (2015). Making a decision to forgive. *Journal of Counseling Psychology, 62*(2), 280-288. <https://doi.org/10.1037/cou0000054>
- Duggi, D. B., & Kamble, S. V. (2014). Decisional and emotional forgiveness in people of three religious groups in India. *Indian Journal of Health and Well-being, 5*(1), 24. <https://doi.org/10.1007/s12144-020-00838-6>
- Enright, R. D. (2019). *Forgiveness is a choice: A step-by-step process for resolving anger and restoring hope*. American Psychological Association.
- Enright, R. D., & Fitzgibbons, R. (2015). *Forgiveness therapy*. Cambridge.
- Enright, R. D., Johnson, J., Na, F., Erzar, T., Hirshberg, M., Huang, T., ... & Zhang, B. (2020). Measuring intergroup forgiveness: The Enright group forgiveness inventory. *Peace and Conflict Studies, 27*(1), 1. <https://doi.org/10.1037/t80714-000>
- Enright, R. D., Lee, Y. R., Hirshberg, M. J., Litts, B. K., Schirmer, E. B., Irwin, A. J., ... & Song, J. Y. (2016). Examining group forgiveness: Conceptual and empirical issues. *Peace and Conflict: Journal of Peace Psychology, 22*(2), 153. <https://doi.org/10.1037/pac0000153>
- Ersanlı, K. & Vural-Batik, M. (2015). Development of the Forgiveness Scale: A study of reliability and validity. *International Periodical For The Languages, Literature and History of Turkish or Turkic, 10*(7), 19-32. <http://dx.doi.org/10.7827/TurkishStudies.8201>
- Fraenkel, J. R., Wallen, N. E., & Hyun, H. H. (2011). *How to design and evaluate research in education (8th Edition)*. McGraw-Hill.
- Gámiz, M., Fernández-Capo, M., Buechner, V. L., et al. (2022). The role of making a decision to forgive in the process of forgiveness: A longitudinal study. *Current Psychology, 41*, 3363–3373. <https://doi.org/10.1007/s12144-021-02421-z>
- George, D., & Mallery, P. (2019). *IBM SPSS statistics 26 step by step: a simple guide and reference (16th ed.)*. Routledge. <https://doi.org/10.4324/9780429056765>
- Gilo, T., Feigelman, W., & Levi-Belz, Y. (2020). Forgive but not forget: From self-forgiveness to posttraumatic growth among suicide-loss survivors. *Death Studies, 46*, 1870-1879. <https://doi.org/10.1080/07481187.2020.1864064>.
- Ha, N., Bae, S., & Hyun, M. (2019). The effect of forgiveness writing therapy on posttraumatic growth in survivors of sexual abuse. *Sexual and Relationship Therapy, 34*, 10-22. <https://doi.org/10.1080/14681994.2017.1327712>.
- Havare, A. Ö. ve Gizir, C. A. (2020). Başkalarını affetme ölçeği ve kendini affetme ölçeği'ni Türkçe'ye uyarlama çalışmaları (Turkish adaptation studies of the rye forgiveness scale and the state self-forgiveness scale). *Hayef: Journal of Education, 17*(2), 150-175. <https://doi.org/10.5152/hayef.2020.20011>
- Hook, J. N., Worthington, E. L., Jr., & Utsey, S. O. (2009). Collectivism, forgiveness, and social harmony. *The Counseling Psychologist, 37*(6), 821–847. <https://doi.org/10.1177/0011000008326546>



- Hu, L. T., & Bentler, P. M. (1999). Cutoff criteria for fit indexes in covariance structure analysis: Conventional criteria versus new alternatives. *Structural Equation Modeling: A Multidisciplinary Journal*, 6(1), 1-55. <https://doi.org/10.1080/10705519909540118>
- Ikedo, F., Castro, L., Fráguas, S., Rego, F., & Nunes, R. (2020). Cross-cultural adaptation and validation of the European Portuguese version of the heartland forgiveness scale. *Health and Quality of Life Outcomes*, 18. <https://doi.org/10.1186/s12955-020-01531-9>
- Kararırmak, Ö., & Güloğlu, B. (2014). Forgiveness and PTSD among veterans: The mediating role of anger and negative affect. *Psychiatry Research*, 219, 536-542. <https://doi.org/10.1016/j.psychres.2014.05.024>.
- Kaya, Ö. S. (2019). Kişilerarası ilişkilerde affetme ölçeği: Geçerlik ve güvenilirlik çalışması (The scale of forgiveness on interpersonal relationships: A validity and reliability study). *İlköğretim Online*, 18(3), 1244-1259. <https://doi.org/10.17051/ilkonline.2019.611538>
- Kline, R. B. (2015). *Principles and practice of structural equation modeling*. Guilford publications.
- Lee, J., & Kim, J. (2021). Korean Christian young adults' religiosity affects posttraumatic growth: the mediation effects of forgiveness and gratitude. *Journal of Religion and Health*, 60, 3967-3977. <https://doi.org/10.1007/s10943-021-01213-w>
- Lichtenfeld, S., Buechner, V. L., Maier, M. A., & Fernández-Capo, M. (2015). Forgive and forget: Differences between decisional and emotional forgiveness. *PLoS One*, 10, e0125561. <https://doi.org/10.1371/journal.pone.0125561>
- Lichtenfeld, S., Maier, M. A., Buechner, V. L., & Fernández-Capo, M. (2019). The influence of decisional and emotional forgiveness on attributions. *Frontiers in Psychology*, 10, 1425. <https://doi.org/10.3389/fpsyg.2019.01425>
- Lin, W., Mack, D., Enright, R., Krahn, D., & Baskin, T. (2004). Effects of forgiveness therapy on anger, mood, and vulnerability to substance use among inpatient substance-dependent clients. *Journal of Consulting and Clinical Psychology*, 72(6), 1114-21. <https://doi.org/10.1037/0022-006X.72.6.1114>.
- López, J., Serrano, M. I., Giménez, I., & Noriega, C. (2021). Forgiveness interventions for older adults: A review. *Journal of Clinical Medicine*, 10(9), 1866. <https://doi.org/10.3390/jcm10091866>
- McCullough, M. (2001). Forgiveness: Who does it and how do they do it? *Current Directions in Psychological Science*, 10, 194-197. <https://doi.org/10.1111/1467-8721.00147>.
- McCullough, M. E., Pargament, K. I., & Thoresen, C. E. (2000). *Forgiveness: Theory, research, and practice*. Guilford Press.
- Mróz, J., Kaleta, K., & Sołtys, E. (2022). Decision to forgive scale and emotional forgiveness scale in a Polish sample. *Current Psychology*, 41(8), 3443-3451. <https://doi.org/10.1007/s12144-020-00838-6>
- Murray, R. (2002). Forgiveness as a therapeutic option. *The Family Journal*, 10, 315-321. <https://doi.org/10.1177/10680702010003008>.
- Noreen, S., & MacLeod, M. D. (2021). Moving on or deciding to let go? A pathway exploring the relationship between emotional and decisional forgiveness and intentional forgetting. *Journal of Experimental Psychology: Learning, Memory, and Cognition*, 47(2), 295-315. <https://doi.org/10.1037/xlm0000948>
- Nunnally, J. (1978). *Psychometric methods*. McGraw-Hill.
- Perez, M. A., & Padilla, A. M. (2023). Multicultural personality and intergroup forgiveness between United States and South African samples. *Journal of Applied Social Psychology*, 53(4), 289-306. <https://doi.org/10.1111/jasp.12870>
- Prochaska, J. O., & DiClemente, C. C. (1982). Transtheoretical therapy: Toward a more integrative model of change. *Psychotherapy: Theory, Research, & Practice*, 19, 276-288. <http://dx.doi.org/10.1037/h0088437>
- Rainey, C. A., Readdick, C. A., & Thyer, B. A. (2012). Forgiveness-based group therapy: A meta-analysis of outcome studies published from 1993-2006. *Best Practices in Mental Health*, 8(1), 1-47.

- Recoder, S., Gámiz, M., Worthington, E. L., Davis, D. E., & Fernández-Capo, M. (2021). Decisional forgiveness across Spanish and American samples: Translation, validation, and measurement invariance of the Decision to Forgive Scale. *Current Psychology*, 40(8), 4125-4135. <https://doi.org/10.1007/s12144-019-00368-w>
- Ripley, J. S., & Worthington, E. L., Jr. (2002). Hope-focused and forgiveness-based group interventions to promote marital enrichment. *Journal of Counseling & Development*, 80(4), 452-463. <https://doi.org/10.1002/j.1556-6678.2002.tb00212.x>
- Sandage, S. J., Hill, P. C., & Vang, H. C. (2003). Toward a multicultural positive psychology: Indigenous forgiveness and Hmong culture. *The Counseling Psychologist*, 31(5), 564-592. <https://doi.org/10.1177/0011000003256350>
- Skalski-Bednarz, K., & Struś, K. (2024). Effects of Christian REACH forgiveness intervention to reduce interpersonal stress on well-being. *Psychology in the Schools*, 61(1), 45-60. <https://doi.org/10.1002/pits.22673>
- Svalina, S., & Webb, J. (2012). Forgiveness and health among people in outpatient physical therapy. *Disability and Rehabilitation*, 34, 383-392. <https://doi.org/10.3109/09638288.2011.607216>.
- Tabacknick, B. G., & Fidell, F. S. (2013). *Using multivariate statistics* (6th ed.). Pearson.
- Thompson, L. Y., Snyder, C. R., Hoffman, L., Michael, S. T., Rasmussen, H. N., & Billings, L. S. (2005). Dispositional forgiveness of self, others, and situations. *Journal of Personality*, 73(2), 313-359. <https://doi.org/10.1111/j.1467-6494.2005.00311.x>
- Toussaint, L. L., & Williams, D. R. (Eds.). (2015). *Forgiveness and health: Scientific evidence and theories relating forgiveness to better health*. Springer.
- Wang, W., Liu, S., Worthington, E., & Li, H. (2022). The validation of the decisional and emotional forgiveness scale among a Chinese sample: The mediating role of forgiveness between stress perception and resilience. *International Journal of Environmental Research and Public Health*, 19. <https://doi.org/10.3390/ijerph192316267>
- Ward, P., Clark, T., Zabriskie, R., & Morris, T. (2014). Paper/pencil versus online data collection. *Journal of Leisure Research*, 46, 105-84. <https://doi.org/10.1080/00222216.2014.11950314>
- Weigold, A., Weigold, I., & Russell, E. (2013). Examination of the equivalence of self-report survey-based paper-and-pencil and internet data collection methods. *Psychological Methods*, 18(1), 53-70. <https://doi.org/10.1037/a0031607>.
- Worthington, E. L. (2005). More questions about forgiveness: Research agenda for 2005-2015. In E. L. Worthington, (Ed.) *Handbook of forgiveness*, (pp. 557-573). Routledge.
- Worthington, E. L., Jr., & Wade, N. G. (Eds.). (2020). *Handbook of forgiveness (2nd ed.)*. Routledge.
- Worthington, E. L., Jr., Witvliet, C. V. O., Pietrini, P., & Miller, A. J. (2007). Forgiveness, health, and well-being: A review of evidence for emotional versus decisional forgiveness, dispositional forgivingness, and reduced unforgiveness. *Journal of Behavioral Medicine*, 30, 291-302. <http://dx.doi.org/10.1007/s10865-007-9105-8>
- Wu, Q., Chi, P., Lin, X., et al. (2022). Gratitude and satisfaction in romantic relationships: Roles of decisional forgiveness and emotional forgiveness. *Current Psychology*, 41, 2668-2676. <https://doi.org/10.1007/s12144-020-00780-7>
- Ye, Y., Tong, Z., Li, C., Gao, X., Sun, Y., Xu, J., Xu, Q., & Song, C. (2022). Social support as a mediator of the relationship between forgiveness and posttraumatic growth in hemodialysis patients: A structural equation modeling approach. *Frontiers in Psychiatry*, 13. <https://doi.org/10.3389/fpsy.2022.974045>.
- Note: It is optional to obtain additional permission from the authors to use the scale. The scale can be used for scientific purposes and following ethical principles

**Table 4:** Scale Items

	Kesinlikle Katılmıyorum	Katılmıyorum	Kararsızım	Katılıyorum	Kesinlikle Katılıyorum
Sizi incitmiş olan kişiye karşı şu andaki niyetinizi düşünün. Aşağıdaki ifadelerden hangisine ne kadar katıldığınızı veya katılmadığınızı belirtin.					
1. Onu affetmeye karar verdim.					
2. Onu affetmek için kendime söz verdim.					
3. Onu affetmeyi aklıma koydum.					
4. Benim tercihim onu affetmektir.					
5. Benim tercihim sahip olduğum olumsuz duygulardan kurtulma yönünde.					
6. Ona karşı kasten kırgınlık beslememeyi seçtim.					