



Turkish adaptation and psychometric testing of the Awareness of Age-Related Change Scale

Fatma Zehra Genç¹ · Suzan Yıldız² · Naile Bilgili³

Accepted: 30 July 2023

© The Author(s), under exclusive licence to Springer Science+Business Media, LLC, part of Springer Nature 2023

Abstract

Awareness of age-related change (AARC) is a multidimensional concept that evaluates the experiences of aging. Accordingly, this study aimed to adapt the long (AARC-50) and short (AARC-10) forms of the AARC scale for the Turkish population and evaluate their psychometric testing. This study included 570 individuals aged 40–92 years. The data of this study were obtained online by the snowball method. Data for this study were collected using the personal information form, AARC scale, and SF-12 quality of life scale. The form was translated and back-translated, expert opinions were obtained, and criterion-related validity, factor, test–retest, and reliability coefficient analyses were performed. Notably, the Cronbach's alpha values of the two-factor 50- and 10-item scales were 0.923 and 0.717, respectively. The correlation of AARC with SF-12 varies between 0.035 and 0.528. In addition, the test–retest reliability score and content validity index were 0.90. Regarding the results of the factor analyses for the long and short forms, the long form demonstrated good results in terms of the chi-square divided by degrees of freedom and root mean square error of approximation, whereas the short form demonstrated good results in terms of goodness (comparative, normal, and adjustment goodness-of-fit index) and standardized root mean square residual. This study found that the AARC-50 and AARC-10 scales are valid and reliable tools for evaluation in the Turkish population. In the future studies, researchers can choose the appropriate form based on the conditions of their studies.

Keywords Measurement adaptation · Self-perceptions of aging · Attitudes toward aging

Introduction

Awareness of age-related change (AARC) is defined as the awareness of changes in one's behavior, levels of performance, or ways of experiencing life as a result of aging. In terms of AARC, individual experiences of aging may change in relation to the following five behavioral domains: health and physical functioning, cognitive functioning, interpersonal relationships, social-cognitive and social-emotional functioning, and lifestyle and engagement (Diehl & Wahl, 2010). In the AARC concept, individuals experience high awareness of age-related change. This situation increases the

motivation of individuals to take health-promoting interventions (Sabatini et al., 2020a). AARC was designed to recognize the possibility that positive and negative age-related changes can occur simultaneously in the same domain of behavior. In particular, it focuses on the conscious self-perception of aging and attempts to identify the self-reflective form of the individual's view of their own aging (Diehl et al., 2014; Wilton-Harding & Windsor, 2022). Accurate assessment of AARC is important. For this purpose, the AARC scale was developed, and it allows adults to assess their own perceptions of aging more accurately and in more detail. This tool was designed for adults of different ages considering that it would help to understand how self-perceptions can function as psychological mechanisms and which aspects of self-perceptions are most relevant for health and well-being in later life (Brothers et al., 2019).

The AARC scale is available in different versions of lengths and has two subscales (gains and losses) and five sections (health and physical functioning, cognitive functioning, interpersonal relationships, social-cognitive and social-emotional functioning, and lifestyle and engagement).

✉ Fatma Zehra Genç
fatmazehragnc@gmail.com; fgenc@erbakan.edu.tr

¹ Department of Public Health Nursing, Faculty of Nursing, Necmettin Erbakan University, Konya, Turkey

² Reşadiye Vocational School, Tokat Gaziosmanpaşa University, Tokat, Turkey

³ Department of Public Health Nursing, Faculty of Nursing, Gazi University, Ankara, Turkey

It is a five-point Likert scale comprising 50 items that are scored between 1 (not at all) and 5 (very much) (Brothers et al., 2019). Kaspar et al. (2019) created a 10-item short form of this scale. The scale was originally developed in Germany and the USA, and the short form of the scale has been adapted in Iran (Nosrati et al., 2022), the UK (Sabatini et al., 2020b), Brazil (Neri et al., 2021), and China (Zhang & Wood, 2022).

To the best of our knowledge, no version of the AARC scale has been adapted in Turkey, where the proportion of older adults is increasing. We believe that this scale can be used in Turkey and will raise awareness about healthy aging. In addition, studies in many countries have used the short form of the scale; however, there are no studies that rate the 50- and 10-item forms of the scale together. Therefore, this study aimed to adapt the AARC-50 scale—developed by Brothers et al. (2019)—and the AARC-10 scale—developed by Kaspar et al. (2019)—for the Turkish population and to examine the psychometric properties of the scales.

Purpose of the study

This study was conducted to adapt the AARC scale (AARC-50) and its short form (AARC-10) into Turkish as well as to examine the psychometric properties of the scales.

Research questions were as follows:

- Is the AARC-50 scale a valid and reliable tool for use in the Turkish population aged ≥ 40 years?
- Is the AARC-10 scale a valid and reliable tool for use in the Turkish population aged ≥ 40 years?
- Is there a relationship between the scores on the AARC-50 and AARC-10 scales and the score on SF-12 quality of life scale?

Materials and methods

Type of research

This was a methodological study. The stages and analyses proposed by the COSMIN checklist (Terwee et al., 2012; Gagnier et al., 2021) were taken into account and reported in the present study (Appendix Table 4).

Stages for validity

Content validity

Translation and back-translation The translation process was performed according to the steps suggested by Bracken

and Barona (1991). The raw Turkish translation was performed by three nursing experts, and the text was back-translated into English by two independent experts.

Expert opinions The scale was sent to experts in the field for obtaining their opinions. In addition, the scale was evaluated in terms of Turkish language by two Turkish language and literature experts. Opinions were obtained from nine experts, and the scale's content validity index (CVI) was calculated. Using the Davis technique, the number of experts who scored each item 3 (pretty appropriate) and 4 (extremely appropriate) was divided by the total number of experts who scored that item (Davis, 1992).

Criterion-related/Concurrent validity

The AARC-50 and AARC-10 scores were compared with the SF-12 quality of life scale score, and the correlations between the scores obtained from these scales were assessed.

Construct validity

Confirmatory factor analysis (CFA) was used to assess construct validity.

Stages for reliability

Immutability

We used the intermittent method for test–retest analysis of the scale. A total of 50 individuals participated in the evaluation of the scale. Notably, retest was conducted 15 days after the first application of the test.

Internal consistency

For internal consistency, Cronbach's alpha (α) reliability coefficient and reliability of total score of items were evaluated.

Population and sample of the study

This study included people aged ≥ 40 years and living in Turkey. Regarding the relevant literature on scale-development studies, there are different opinions on sample selection. One strategy indicates that the number of participants should be 10 times the number of scale items (Hair et al., 2010). Thus, in this study, data were collected from 570 individuals.

Location and characteristics of the research

This research was conducted online. A form was created using Google Drive, and the information about and link to

the form were shared with individuals using the snowball method.

Inclusion criteria

The inclusion criteria were as follows: people aged ≥ 40 years, those who volunteered to participate, and those who did not have any problems that would have prevented them from completing the online questionnaire.

Data collection forms and data collection

The forms used for collection of research data were prepared based on the relevant literature (Brothers et al., 2019; Kaspar et al., 2019; Sabatini et al., 2020a, b; Calik et al., 2022).

Personal information form

This form comprises seven questions on personal characteristics, such as age, perceived age, and gender.

AARC scale

AARC refers to the state of awareness that one's behavior, level of performance, or way of experiencing life has changed as a result of aging. The AARC scale includes two sub-dimensions. These dimensions include both positive (AARC gains) and negative (AARC losses) aspects of one's aging experiences. In addition, the scale assesses five domains and is a five-point Likert scale with 50- and 10-item forms (Brothers et al., 2019; Kaspar et al., 2019). The five domains are health and physical functioning (perceived changes in physical appearance and health and physical functioning), cognitive functioning (perceived changes in all cognitive processes and abilities, including processes related to the central nervous system function), interpersonal relationships (changes in social relationships and perceived changes in interactions and communication), social-cognitive and social-emotional functioning (perceived changes related to self-aging self and emotional domain), and lifestyle and engagement (perceived changes related to overall behavior in day-to-day life) (Diehl & Wahl, 2010; Brothers et al., 2019; Kaspar et al., 2019). Notably, participants rated items from 1 to 5 (1, never; 5, very much) in relation to how their lives might change as a result of aging. The α value of the scale varies between 0.73 and 0.89 (Brothers et al., 2019).

SF-12 quality of life scale

The 36-item form of the scale was developed by Ware and Sherbourne in 1992 (Ware & Sherbourne, 1992), and a 12-item short form for adults was developed by them in

1995. This scale includes the following eight sub-dimensions: physical and social functioning, physical and emotional role (role limitation due to physical and emotional problems), general and mental health, body pain, and energy. Further, this scale was adapted in Turkish by Soylu and Kütük (2021) and reported to be suitable for use in adults (Soylu & Kütük, 2021; Bahadır et al., 2021). SF-12 includes 8 sub-dimensions and 12 items, including physical functioning (2 items), physical role (2 items), body pain (1 item), general health (1 item), energy (1 item), social functioning (1 item), emotional role (2 items), and mental health (2 items). Specifically, the items related to the physical and emotional roles are answered as yes or no, and the other items are multiple choice questions with scores ranging from 3 to 6. The score of the physical component of SF-12 is based on the general health, physical functioning, physical role, and body pain sub-dimensions, whereas that of its mental component is based on the social functioning, emotional role, mental health, and energy sub-dimensions. Both the physical and mental component scores range from 0 to 100, with a higher score indicating better health. The α values of the scale were found to be satisfactory ($\alpha = 0.73$ and $\alpha = 0.72$ for the physical and mental components, respectively) (Soylu & Kütük, 2021).

Ethical dimension of research

Before starting the study, ethical approval was obtained from the Gazi University Ethics Commission (Research Code No: 2022 – 149). Permissions were obtained from the researchers who developed the AARC-50 and AARC-10 scales for adaptation into Turkish. Moreover, permission was obtained for the use of the SF-12 quality of life scale in this study. It was obtained by ticking the online “Informed Voluntary Consent Form” checkbox of the participants.

Limitations of the study

This research can only be generalized to the studied sample. As the data were collected online, individuals who did not have internet access could not be approached.

Statistical analysis

The data were analyzed using IBM SPSS V23 and IBM AMOS. To determine the suitability of the data for principal component analysis, α coefficient was used to provide evidence of internal consistency—a measure of accuracy. Test–retest reliability was used to determine the consistency of the developed tool despite changing conditions and circumstances. In addition, item–test correlations were used to demonstrate the validity of each item. CFA was performed to provide evidence stating that the scale

can provide the same structure in similar groups. Finally, a correlation analysis between the AARC-50, AARC-10, and SF-12 quality of life scales was performed. As the multivariate normality assumption was not met in the AARC-50 scale, bootstrap maximum likelihood (ML) was used as the calculation method, and 5000 resamples were preferred in the bootstrap analysis. Notably, the multivariate normality assumption was met in AARC-10, and ML was used. A p -value of <0.05 was considered statistically significant for all analyses.

Results

The mean age of the participants was 53.4 ± 10.4 (median: 51.5, range: 40–92) years, and the mean perceived age was 44.8 ± 13.9 (median: 45, range: 12–100) years. Overall, 63.3%, 92.8%, 46%, and 48.1% of the participants were men, married, college graduates, and full-time employees, respectively. In total, 68.9% of the participants thought that aging has more positive aspects.

Findings regarding the validity of the scale

Construct validity of the AARC-50 scale

Any issues related to the data, such as outliers, skewness and kurtosis, missing data, etc., should be resolved before performing the CFA. In addition, to use ML, the data must conform to a normal distribution. In the multivariate normality test, the critical value was found to be 80.052. A previous study reported that a score of <10 indicates an excellent result, and a score of <20 is generally not a problem (Gürbüz, 2021). Furthermore, as the multivariate normality assumption was not met, bootstrap ML was used as the calculation method, and 5000 resamples were preferred in the bootstrap analysis. Regarding the examination of the first-level CFA results of the scale, which consists of 50 items and 2 factors, the scores of the model fit indices after three different modifications were as follows: chi-square divided by degrees of freedom (CMIN/DF; χ^2/df), 3.077; comparative fit index (CFI), 0.785; goodness of fit (GFI), 0.770; root mean square error of approximation (RMSA), 0.060; and standardized root mean squared residual (SRMR), 0.081. Notably, all model fit scores were within acceptable limits, except for CFI and GFI. In addition, all standardized (Figs. 1 and 2) and non-standardized (Appendix Figs. 3 and 4) path coefficients of the scale items were statistically significant ($p < 0.001$, Table 1). Examination of the standardized path coefficients indicated that item y_36

had the strongest effect on F1 and item y_23 the strongest effect on F2.

Construct validity of the AARC-10 scale

A two-factor structure was identified for the AARC-10 scale, and five items were included under each factor in this structure. In addition, the multivariate normality assumption was fulfilled in this structure with a critical value of 18.302 (Gürbüz, 2021). The results of the fit indices were as follows: CMIN/DF, 3.661; RMSA, 0.068; CFI, 0.931; and GFI 0.958; NFI, 0.909; and AGFI, 0.932. Moreover, the model fit scores obtained were within the desired limits. In addition, all path coefficients were significant ($p < 0.05$). By examining the standardized path coefficients, it was found that item y_47 had the strongest effect on F1 and item y_12 had the strongest effect on F2 (Table 2; Figs. 1 and 2).

Expert opinions

No separate reviews were obtained for the short and long forms of the AARC scale. We only solicited opinions for the long form of the scale. Nine experts were consulted, and the scale's CVI was calculated. The Davis technique was used for the calculation, and the CVI was found to be 0.90. Based on the expert opinions, an agreement of 90% was achieved for the content validity of the scale.

Criterion-related/Concurrent validity

The AARC-50 and AARC-10 scores were analyzed along with the SF-12 quality of life scale score, and a Pearson correlation analysis was performed. All three measurement tools used in this study have two sub-dimensions. A correlation was found between the SF-12 quality of life scale-physical component dimension and the AARC-50 gains sub-dimension ($r = 0.035$, $p = 0.409$), AARC-50 losses sub-dimension ($r = -0.271$, $p < 0.001$), AARC-10 gains sub-dimension ($r = 0.042$, $p = 0.322$), and AARC-10 losses sub-dimension ($r = -0.283$, $p < 0.001$). Moreover, a correlation was found between the SF-12 quality of life scale-mental component dimension and the AARC-50 gains sub-dimension ($r = 0.113$, $p = 0.007$), AARC-50 losses sub-dimension ($r = -0.528$, $p < 0.001$), AARC-10 gains sub-dimension ($r = 0.051$, $p = 0.225$), and AARC-10 losses sub-dimension ($r = -0.453$, $p < 0.001$).

Findings regarding the reliability of the scale

Findings related to internal consistency were examined by calculating the α coefficient. Notably, internal consistency of a scale increases as the α coefficient approaches 1 (Alpar, 2014). Moreover, the α values of the AARC-50

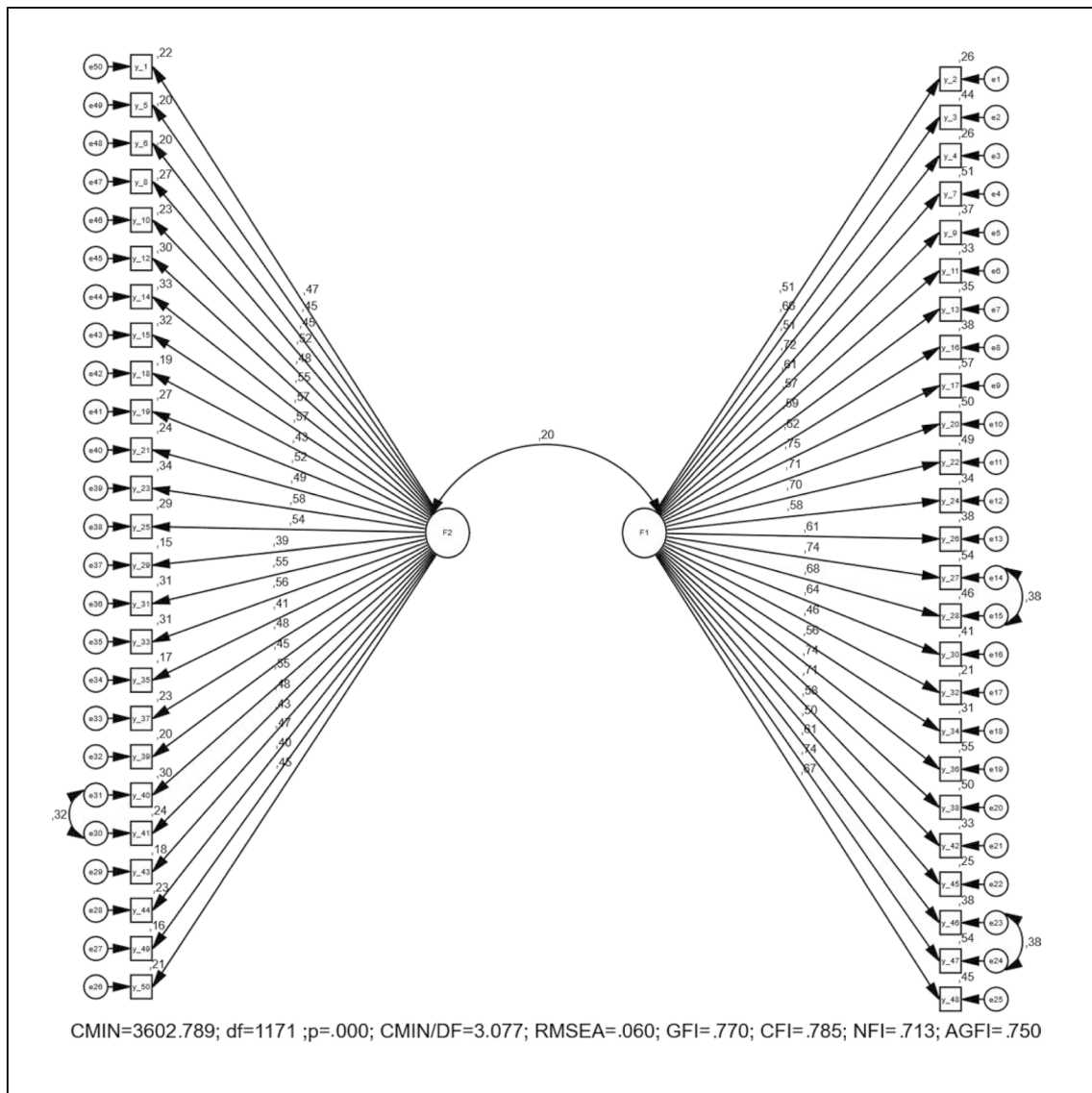

Fig. 1 AARC-50 Standardized path coefficients

scale, AARC-50 gains dimension (F1), and AARC-50 losses dimension (F2) were 0.923, 0.943, and 0.887, respectively. Furthermore, the α values of the AARC-10 scale, AARC-10 gains dimension (F1), and AARC-10 losses dimension (F2) were 0.717, 0.806, and 0.642, respectively.

Test–retest reliability

Test–retest reliability was analyzed to determine the consistency of the tool developed in this study despite changing conditions and circumstances. After 14 days, the scale was administered to 50 individuals. The results of this study were analyzed using correlation analysis. Notably, consistency

increased as the correlation coefficient approached the value of 1. Moreover, the correlation coefficient between the test and retest scores was found to be 0.90 ($p < 0.001$; $n = 570$). The critical value for the Pearson correlation analysis is 0.70, and it was determined that the adapted scale demonstrated a high degree of correlation.

Discussion

By assessing a multidimensional construct related to age, AARC emphasizes that aging is not always a negative process and that humans can play a positive role in influencing the aging process (Brothers et al., 2016;

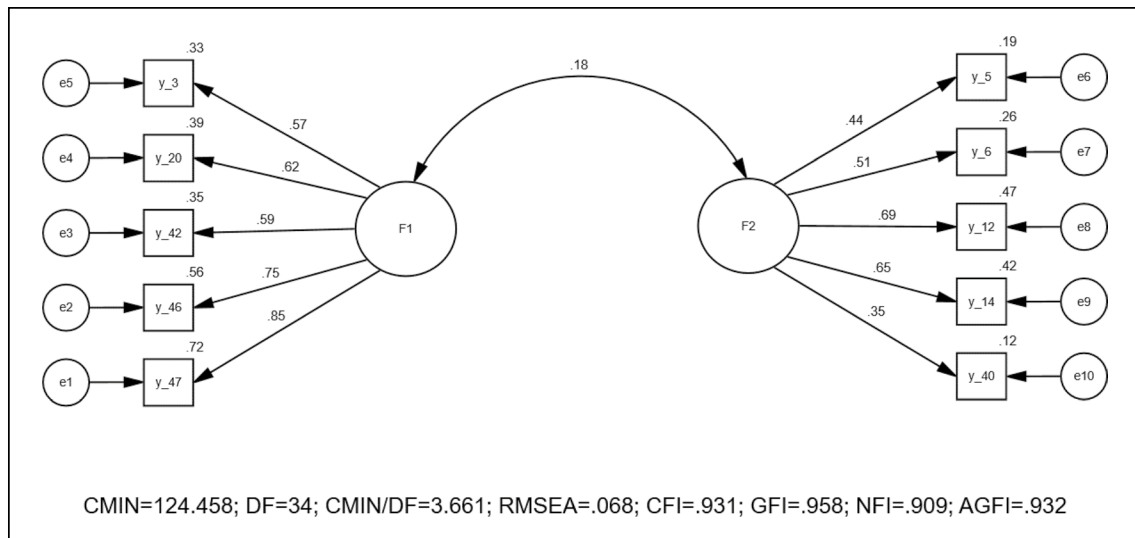

Fig. 2 AARC-10 Standardized path coefficients

Nosrati et al., 2022). Additionally, AARC is a measure of perceived aging and does not involve measuring subjective age solely for the assessment of the feelings of older adults. Moreover, AARC is distinctive because it identifies specific psychological and behavioral conditions that make individuals age-conscious (Brothers et al., 2016). In this context, the experience of aging can affect health and well-being of such individuals, and based on this idea, the present study aimed to evaluate the reliability and validity of the AARC-50 and AARC-10 measurement tools for adults living in Turkey.

The AARC scale has been most commonly used in the USA, the UK, and Germany, and it examines participants with an average age of 65 years who are concerned about physical or mental health outcomes (Sabatini et al., 2020b). In the present study, the mean age of the participants was 53.4 years, > 50% participants were men, most participants were married, and almost 50% participants were university graduates and had full-time jobs. Notably, the present study enrolled 570 individuals, and > 50% of the participants thought that aging had more positive aspects. The AARC-50 scale was developed by Brothers et al. (2019) in a study involving 424 individuals aged 40–98 years in Germany. In their study, the mean age of the participants was 69.53 years, > 50% participants were married and retired, and only a small number of participants had full-time jobs (Brothers et al., 2019). Furthermore, Kaspar et al. (2019) developed the short form of the AARC scale in a study involving 819 individuals from

Germany and North America. In their study, the age of the participants was 40–98 (average, 64.13) years. In addition, > 50% of the participants were German and married, and 40.8% participants had a high level of education (Kaspar et al., 2019). In a validity and reliability study conducted in Iran, 352 individuals were examined, and > 50% of the participants were women (Nosrati et al., 2022). Similarly, the short form of the scale was assessed in a study involving 387 individuals from Brazil who were aged ≥ 60 years. In that study, the average age of the participants was 67.9 years, and > 50% of the participants were women, married, and retired (Neri et al., 2021). AARC-10 was also adapted for the Chinese population in a study involving 421 individuals; it was determined that the average age of the participants was 41 years, and > 50% were women and had undergraduate level of education (Zhang & Wood, 2022). Sabatini et al. (2020) conducted a study on 9410 individuals to validate the AARC-10 scale in the UK population aged ≥ 50 years. In their study, the average age of the participants was 65.9 years, and > 80% participants were women, Caucasian, and married (Sabatini et al., 2020b).

In other validity and reliability studies, no expert opinion was sought and no findings on CVI were reported in line with the opinions (Neri et al., 2021; Nosrati et al., 2022; Zhang & Wood, 2022). In the present study, based on the expert opinions, 90% agreement was found for the content validity of the scale. Nosrati et al. (2022) adapted the scale in a parallel scale study and found a significant association between perceptions

Table 1 Confirmatory factor analysis findings of the AARC-50 scale

Item	Factor	β_1 (95% CI)	β_2 (95% CI)	SE	Test statistic	p
y_2	F1	1 (1–1)	0.514 (0.44–0.583)	0.036		...
y_3	F1	1.416 (1.199–1.708)	0.665 (0.609–0.716)	0.027	11.509	<0.001
y_4	F1	1.22 (1.013–1.485)	0.508 (0.438–0.572)	0.035	9.733	<0.001
y_7	F1	1.538 (1.323–1.826)	0.717 (0.663–0.766)	0.026	11.989	<0.001
y_9	F1	1.283 (1.083–1.541)	0.609 (0.545–0.669)	0.031	10.941	<0.001
y_11	F1	1.214 (1.008–1.481)	0.574 (0.51–0.637)	0.033	10.551	<0.001
y_13	F1	1.318 (1.125–1.572)	0.593 (0.534–0.647)	0.029	10.764	<0.001
y_16	F1	1.409 (1.186–1.703)	0.617 (0.555–0.676)	0.031	11.023	<0.001
y_17	F1	1.576 (1.35–1.883)	0.752 (0.711–0.79)	0.02	12.278	<0.001
y_20	F1	1.469 (1.258–1.768)	0.709 (0.654–0.758)	0.027	11.92	<0.001
y_22	F1	1.332 (1.15–1.579)	0.7 (0.651–0.743)	0.023	11.834	<0.001
y_24	F1	1.203 (1.008–1.456)	0.581 (0.511–0.644)	0.034	10.634	<0.001
y_26	F1	1.112 (0.938–1.331)	0.614 (0.549–0.675)	0.032	10.995	<0.001
y_27	F1	1.458 (1.257–1.731)	0.736 (0.69–0.779)	0.023	12.148	<0.001
y_28	F1	1.327 (1.135–1.589)	0.681 (0.63–0.728)	0.025	11.661	<0.001
y_30	F1	1.368 (1.152–1.653)	0.642 (0.583–0.694)	0.028	11.285	<0.001
y_32	F1	0.976 (0.769–1.237)	0.461 (0.388–0.532)	0.037	9.094	<0.001
y_34	F1	1.131 (0.928–1.379)	0.561 (0.499–0.623)	0.032	10.4	<0.001
y_36	F1	1.569 (1.353–1.868)	0.738 (0.696–0.779)	0.021	12.168	<0.001
y_38	F1	1.499 (1.274–1.797)	0.701 (0.657–0.757)	0.025	11.923	<0.001
y_42	F1	1.321 (1.091–1.605)	0.578 (0.507–0.646)	0.035	10.601	<0.001
y_45	F1	0.977 (0.778–1.216)	0.498 (0.415–0.576)	0.041	9.602	<0.001
y_46	F1	1.235 (1.046–1.489)	0.614 (0.55–0.673)	0.031	10.992	<0.001
y_47	F1	1.525 (1.307–1.81)	0.736 (0.689–0.779)	0.023	12.151	<0.001
y_48	F1	1.406 (1.185–1.699)	0.669 (0.617–0.718)	0.026	11.555	<0.001
y_50	F2	1 (1–1)	0.454 (0.354–0.543)	0.048		...
y_49	F2	1.112 (0.826–1.507)	0.404 (0.299–0.499)	0.051	7.485	<0.001
y_44	F2	1.226 (0.961–1.609)	0.475 (0.382–0.553)	0.044	8.302	<0.001
y_43	F2	1.223 (0.92–1.697)	0.43 (0.348–0.506)	0.041	7.799	<0.001
y_41	F2	1.336 (1.046–1.793)	0.485 (0.404–0.559)	0.04	8.4	<0.001
y_40	F2	1.554 (1.185–2.143)	0.548 (0.468–0.62)	0.039	9.001	<0.001
y_39	F2	1.165 (0.88–1.558)	0.447 (0.347–0.532)	0.048	8.001	<0.001
y_37	F2	1.295 (0.972–1.815)	0.483 (0.392–0.565)	0.044	8.391	<0.001
y_35	F2	1.275 (0.929–1.836)	0.407 (0.326–0.48)	0.039	7.524	<0.001
y_33	F2	1.429 (1.122–1.915)	0.559 (0.486–0.627)	0.036	9.099	<0.001
y_31	F2	1.511 (1.172–2.069)	0.553 (0.476–0.623)	0.038	9.05	<0.001
y_29	F2	1.129 (0.775–1.663)	0.388 (0.295–0.478)	0.047	7.276	<0.001
y_25	F2	1.536 (1.215–2.059)	0.539 (0.463–0.608)	0.037	8.925	<0.001
y_23	F2	1.491 (1.204–1.95)	0.583 (0.497–0.655)	0.04	9.299	<0.001
y_21	F2	1.246 (0.972–1.653)	0.49 (0.397–0.571)	0.044	8.461	<0.001
y_19	F2	1.427 (1.102–1.948)	0.519 (0.432–0.6)	0.043	8.744	<0.001
y_18	F2	1.126 (0.819–1.583)	0.432 (0.343–0.516)	0.044	7.829	<0.001
y_15	F2	1.586 (1.231–2.177)	0.568 (0.499–0.632)	0.034	9.179	<0.001
y_14	F2	1.355 (1.088–1.764)	0.575 (0.494–0.646)	0.039	9.231	<0.001
y_12	F2	1.235 (0.955–1.664)	0.548 (0.469–0.617)	0.037	9.006	<0.001
y_10	F2	1.25 (0.966–1.69)	0.478 (0.385–0.559)	0.044	8.339	<0.001
y_8	F2	1.391 (1.085–1.874)	0.519 (0.438–0.592)	0.039	8.743	<0.001
y_6	F2	1.063 (0.764–1.487)	0.448 (0.353–0.538)	0.047	8.005	<0.001
y_5	F2	1.273 (0.944–1.774)	0.453 (0.367–0.53)	0.042	8.063	<0.001
y_1	F2	1.235 (0.926–1.701)	0.468 (0.383–0.545)	0.042	8.226	<0.001

β_1 : Non-standardized path coefficients; β_2 : Standardized path coefficients, CI: Confidence Interval, SE: Standard Error

Table 2 Confirmatory factor analysis findings of the AARC-10 scale

Item		Factor	β_1 (95% CI)	β_2 (95% CI)	SE	Test statistic	<i>p</i>
y_47	<---	F1	1 (1–1)	0.847 (0.797–0.984)			---
y_46	<---	F1	0.859 (0.771–0.949)	0.749 (0.690–0.803)	0.049	17.539	<0.001
y_42	<---	F1	0.765 (0.649–0.884)	0.588 (0.510–0.661)	0.056	13.636	<0.001
y_20	<---	F1	0.738 (0.633–0.853)	0.625 (0.551–0.696)	0.051	14.576	<0.001
y_3	<---	F1	0.693 (0.582–0.813)	0.571 (0.494–0.645)	0.052	13.195	<0.001
y_5	<---	F2	1 (1–1)	0.436 (0.321–0.554)			---
y_6	<---	F2	0.991 (0.770–1.287)	0.511 (0.391–0.642)	0.138	7.187	<0.001
y_12	<---	F2	1.262 (0.873–1.820)	0.686 (0.590–0.767)	0.16	7.885	<0.001
y_14	<---	F2	1.246 (0.848–1.827)	0.648 (0.533–0.748)	0.159	7.827	<0.001
y_40	<---	F2	0.816 (0.525–1.202)	0.353 (0.246–0.454)	0.141	5.802	<0.001

β_1 : Non-standardized path coefficients; β_2 : Standardized path coefficients, CI: Confidence Interval, SE: Standard Error

of aging and the AARC-10 scale score. Kaspar et al. (2019) used the AARC-50 (long form) and SF-36 quality of life scales as parallel scales and evaluated their results using Pearson's correlation analysis. A strong significant correlation was found between the gains and losses dimensions of the AARC-10 and AARC-50 scales. Although the correlation between the physical and psychological components of the SF-36 quality of life scale and the loss dimension of the AARC-50 and AARC-10 scales was not strong, their coefficient values were higher than those for the other dimensions ($-0.22 < r < -0.58$) (Kaspar et al., 2019). Neri et al. (2021) found a negative correlation of the frailty and AARC-10 scale scores with the AARC-10 gain score. It has been reported that higher frailty scores indicate higher AARC-10 loss scores. In addition, the higher and more positive the self-reported health status, the higher the AARC-10 and its gain score (Neri et al., 2021). In the present study, a significant correlation was found between the SF-12 quality of life scale-physical component dimension and the AARC-50 and AARC-10 loss scores ($p < 0.001$). Moreover, the SF-12 quality of life scale-mental component dimension was significantly correlated with AARC-50 gains ($p = 0.007$), AARC-50 losses, and AARC-10 losses ($p < 0.001$) scores.

The CFA results of the AARC-50 scale in the German population were as follows: χ^2/df , 1.703; RMSEA, 0.04; CFI, 0.99; and SRMR, 0.003 (Brothers et al., 2019). In contrast, the CFA results of the short form were as follows: χ^2/df , 4.158; RMSEA, 0.062; CFI, 0.95; and TLI, 0.93 (Kaspar et al., 2019). Notably, the CFA results of the short form adapted for the Iranian population were as follows: χ^2/df , 2.54; RMSA, 0.08; NFI, 0.91; GFI, 0.9; and CFI, 0.94 (Nosrati et al., 2022). The CFA results of the Portuguese version of the short form adapted for the older

adults in Brazil were examined in two models. In the first model, the results were $\chi^2/df = 1.360$, GFI = 0.9049, AGFI = 0.8462, CFI = 0.9461, RMSEA = 0.093, and SRMR = 0.0683, whereas those in the second model were $\chi^2/df = 1.046$, GFI = 0.948, AGFI = 0.9104, CFI = 0.9952, RMSEA = 0.020, and SRMR = 0.058 (Neri et al., 2021). Another study conducted with Chinese population revealed that a two-factor AARC model fit the data well, and the CFA results were as follows: $\chi^2/df = 2.35$, $p < 0.001$, CFI = 0.94, RMSEA = 0.06, and SRMR = 0.05 (Zhang & Wood, 2022). In the study conducted in the UK population, it was revealed that a two-factor AARC-10 model provided good fit, and the CFA results were as follows: RMSEA = 0.07, CFI = 0.94, TLI = 0.92, and SRMR = 0.05 (Sabatini et al., 2020b). Notably, CFA results of the present study are consistent with those of other studies in the relevant literature. Regarding the comparison of CFA results of the long and short forms of the scale, it was found that the long form was better in terms of χ^2/df and RMSEA findings, and the short form was better in terms of GFI, CFI, NFI, AGFI, and SRMR (Table 3). Although the long (Brothers et al., 2019) and short (Kaspar et al., 2019) forms of the scale have been developed, adaptation studies for different population groups preferred the short form of the scale. To the best of our knowledge, there are no adaptation studies with the long form of the scale in the literature. In the present study, we provide the validity and reliability results for both the long and short forms of the scale, leaving the choice of scale to future researchers.

Brothers et al. (2019), who developed the original AARC-50 scale, determined the α value of the scale as 0.89 and 0.88 for the gains and losses sub-dimensions, respectively. The α value was not calculated for the short form of the scale (Kaspar et al., 2019), and the value for

Table 3 AARC-50 and AARC-10 goodness of fit indices (Byrne, 2011; Kline, 2015; Gürbüz, 2021)

Goodness of fit indices (FIT)	AARC-50	AARC-10	Good fitness values
χ^2/df	3.077	3.661	< 5
RMSEA	0.060	0.068	< 0.08
GFI	0.770	0.958	> 0.90
CFI	0.785	0.931	> 0.90
NFI	0.713	0.909	> 0.90
AGFI	0.750	0.932	> 0.90
SRMR	0.081	0.051	≤ 0.05

χ^2 : ki kare, χ^2/df : ki kare/ degrees of freedom, RMSEA: Root Mean Square Error of Approximation, GFI: Goodness-of-Fit Index, AGFI: Adjustment Goodness of Fit Index, CFI: Comparative Fit Index, NFI: Normal Fit Index, SRMR: Standard Root Mean square Residual

the short form adapted for the Brazilian population could not be found (Neri et al., 2021). Notably, the α value of the AARC-10 scale adapted for the Iranian population was 0.85 and 0.91 for the gains and losses sub-dimensions, respectively (Nosrati et al., 2022). Zhang and Wood (2022) reported that the α value of the AARC-10 scale adapted for the Chinese population was good. The UK version of the AARC-10 scale had the α value of 0.77 for the gains sub-dimension and 0.80 for the losses dimension (Sabatini et al., 2020b). In the present study, the α value of the AARC-50 and AARC-10 scales were 0.923 and

0.717, respectively, which were similar to the reliability coefficients obtained for different populations. In addition, the α value of the losses sub-dimension was higher in both the short and long forms of the scale. Notably, both measurement tools were found to be reliable for the Turkish population, and it was concluded that researchers can use both measurement tools to measure a multidimensional construct related to age.

Conclusion and recommendations

The AARC-50 and AARC-10 scales are valid and reliable measurement tools for the Turkish population. With the use of both the tools, positive and negative perceptions of age-related changes in different areas of life can be determined. Given the scale's content and ease of use, individuals can change their own feelings about aging. The data generated by the scale can be used in the development of social, organizational, and public policies to better serve the needs of the older adults. Moreover, these tools can be used to raise awareness of age discrimination among individuals and institutions and to make concerted efforts to address this issue. Rather than focusing on chronological age and promoting various measures, the AARC scale can be effective in maximizing positive experiences and minimizing negative experiences of aging. Based on these results, further studies are required to focus on determining age-related awareness in the Turkish population.

Appendix

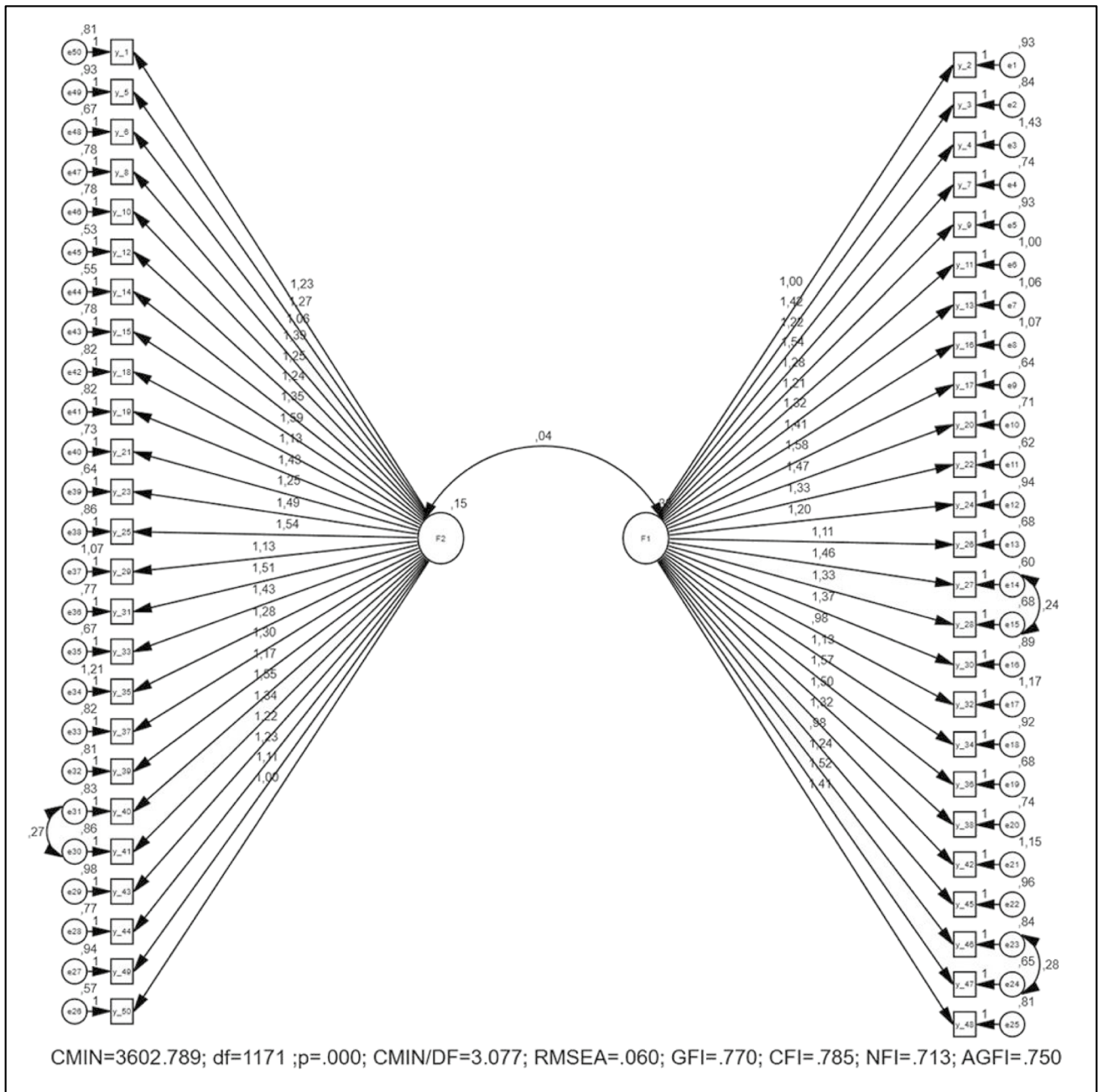

Fig. 3 AARC-50 non-standardized path coefficients

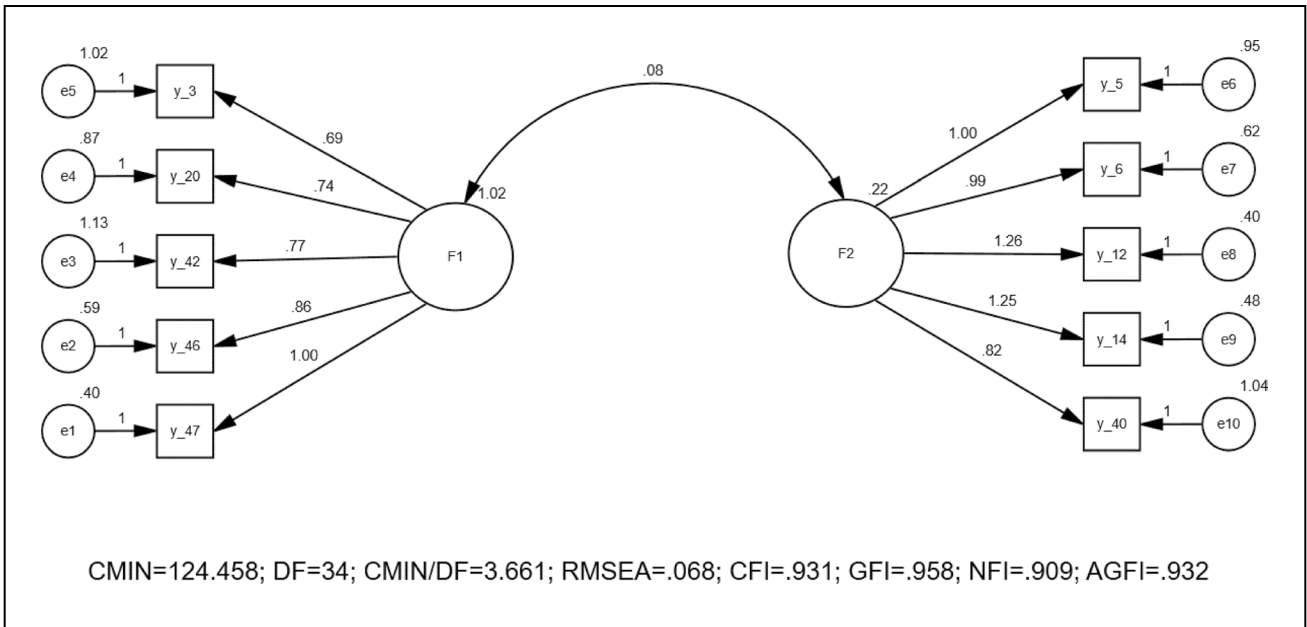

Fig. 4 AARC-10 non-standardized path coefficients

Table 4 COSMIN reporting guideline for studies on measurement properties of patient reported outcome measures

Version August 2021

General reporting recommendations relevant for all studies on measurement properties

Item number	Item name	Item description	Page
Report section: Title			
T1	Patient Reported Outcome Measure (PROM)	The name of the PROM instrument(s) (and version if relevant) being studied	1
T2	Measurement Property (MP)	What MPs are being studied or more generally, that MPs are being studied (if there are many properties being investigated, for example)	1
T3	Study sample	General description of relevant study sample characteristics (e.g., condition of interest, language) and also any intervention or exposure (e.g., treatments) if applicable.	1
Report section: Abstract			
A1	PROM	The name of the PROM instrument(s) (and version if relevant) being studied (i.e. the SF-36 or SF-12; language version) or if it concerns an item bank (e.g., PROMIS instruments). The type of instrument (e.g. a self reported questionnaire or interview).	1
A2	Measurement Property	What MPs are being studied or more generally, that MPs are being studied (if there are many properties being investigated, for example)	1
A3	Design	The type of study being used to test the properties (e.g., test-retest design, longitudinal study, cohort, cross sectional, case series, randomized etc.). Other details of the study design if relevant (intervention/exposure, description of comparison instruments, outcomes other than PROMs).	1
A4	Sample	Inclusion / exclusion criteria. General description of relevant study sample characteristics (e.g., condition of interest, geographic location, language, other relevant demographic and baseline characteristics)	1
A5	Methods	A brief description of the methods for investigating each MP including statistical analyses	1
A6	Results	The main results for all MPs investigated reporting statistics for each result with measures of precision where appropriate.	1
A7	Discussion/Conclusions	A brief description of the results in the context of existing evidence, main strengths and drawbacks and the need for future research on the PROM(s) investigated.	1
Report section: Introduction			
I1	Name and describe the PROM of interest	Specify the name, type, language, and version of the PROM being investigated and how it was developed. Describe the construct the PROM aims to measure and its subscales; describe the structure of the PROM (e.g., the number of factors, the number of items, scoring algorithm); describe relevant instructions (like time period), and number or type of response categories. State whether the PROM is based on a reflective or formative model. Note: This information may also appear in the methods section in greater detail.	1,2
I2	Target population	Describe the specific target population that the PROM was designed for. The authors need to provide the appropriate and necessary characteristics of this population.	2,3
I3	Citation for the original development of the PROM	The citation for the original development paper(s) should be provided - and other highly relevant citations related to the quality of the specific PROM under investigation.	-

Table 4 (continued)

Version August 2021

General reporting recommendations relevant for all studies on measurement properties

Item number	Item name	Item description	Page
I4	State of Knowledge & Rationale	A description of the current scientific knowledge (what is known) regarding the MPs of? the PROM under investigation. The authors should provide a literature review or refer to a recent review of all existing evidence of the specific version (e.g., language, short form) of the PROM and explain why the new study is necessary and important. The rationale for the current proposed study should be given.	1,2
I5	Definitions	Specialized terms should be defined or explained.	1,2,3
I6	Objectives and Hypotheses	State the specific objective(s) of the research and hypotheses related to the specific PROM under investigation.	2
Report section: General Methods			
GM1	Study Design	State the key elements of the study design	3
GM2	Participants	State how the participants were chosen; the inclusion and exclusion criteria. (e.g., if a PROM for a specific condition, then the eligibility and selection criteria should reflect this).	2,3
GM3	PROM administration	An explicit description of how and when the PROM(s) were administered (e.g., in what setting) including data collection devices/system used (e.g. paper based, electronic administration / ePRO) should be provided.	2,3
GM4	Data collection procedures	Provide information about other data collection, exposure methods (e.g., allocation to interventions) and time points / follow-up points.	3
GM5	Power/sample size calculation	Provide a power calculation for all MP analyses. Alternatively, if a rule of thumb is used, state it and the source/citation.	-
GM6	Statistical analyses	Statistical analyses and tests corresponding to all hypotheses or objectives for all MPs should be reported. Where appropriate, a cut-off for statistical significance should be reported (e.g., p-value less than 0.05). A description of all statistics to be used to estimate the magnitude and direction of effect should also be reported, together with measures of variability or precision. Report statistical package used.	3,4
GM7	Missing data	State approaches or plan for dealing with missing data.	-
GM8	Post hoc analysis	The report should specify analyses that used data after the data collection period concluded (i.e., if the analyses were post hoc; secondary data analyses) and describe the rationale for any post hoc analyses.	-
Report section: General Results			
GR1	Missing data	The amount and reasons for missing data should be explained for all analyses for all PROMs (or other outcome measurement instruments) and relevant groups.	-
GR2	Participant/patient Characteristics	The study patients' characteristics should be described, including baseline PROM scores.	4
GR3	Sample size	If one study contained analyses using different sample sizes, the authors should report the sample size for each analysis.	2
Report section: Discussion			
D1	MP evidence	Per measurement property the authors should compare the result to the criteria for good measurement properties (e.g., COSMIN criteria)[27], and determine if the specific MP is sufficient or not. Note: This information may also appear in the results section in greater detail in a table for example.	5,6,7,8,9
D2	Practical relevance	The authors need to discuss the practical relevance of the findings.	3,9
D3	Strengths and limitations	Strengths and limitations of the study should be discussed. For example, discuss if there were any significant potential biases in the study that could have impacted the results.	3,9

Table 4 (continued)

Version August 2021

General reporting recommendations relevant for all studies on measurement properties

Item number	Item name	Item description	Page
D4	Generalizability	Generalizability issues related to the PROM results should be discussed. For example, discuss if the results could be generalized to other populations given the sample studied.	3,9
D5	Instrument changes	Discuss the need for modifications to the existing PROM or new PROM development. If you conclude that one of the measurement properties is insufficient, you could suggest some modification, or if it is really poor, you could suggest stopping use of the PROM (in the specific population or in general).	-
D6	Future Research	Report specifically the type of research needed to answer new questions arising out of these findings for the particular MP and PROM investigated.	9
Report section: Conclusions			
C1	Conclusions	State the overall conclusions for each MP and of the use PROM investigated.	9
Report section: Other information			

Acknowledgements We thank all participants in the present study for their generous cooperation. We thank the AARC research group at Colorado State University, USA, and Heidelberg University, Germany, for their encouragement to translate and validate a Turkish version of the AARC-50 and AARC-10 scale.

Author contribution Fatma Zehra Genç: Conceptualization, Methodology, Investigation, Data curation, Formal analysis, Writing – original draft. Suzan Yıldız: Conceptualization, Methodology, Writing–review & editing. Naile Bilgili: Conceptualization, Methodology, Writing – original draft, Writing –review & editing, Supervision.

Data availability The findings of this study can be obtained from the relevant corresponding author upon request.

Declarations

Ethical approval Before starting the study, ethical approval was obtained from the Gazi University Ethics Commission (Research Code No: 2022 – 149). Permissions were obtained from the researchers who developed the AARC-50 and AARC-10 scales for adaptation into Turkish. Moreover, permission was obtained for the use of the SF-12 quality of life scale in this study. It was obtained by ticking the online “Informed Voluntary Consent Form” checkbox of the participants. Furthermore, participants were informed about the study, and written consent was obtained online.

Conflict of interest We have no conflict of interest to declare.

References

- Alpar, R. (2014). *Uygulamalı İstatistik ve Geçerlik Güvenirlilik*. Detay Yayıncılık.
- Bahadır, Z., Yaran, M., Özkan, E., Ekici, G., Huri, M., & Akel, S. (2021). Translation, psychometric and concept analysis of the occupational balance-questionnaire based on a turkish population.

Occupational Therapy in Health Care, 1–18. <https://doi.org/10.1080/07380577.2021.2010160>

- Bracken, B. A., & Barona, A. (1991). State of the art procedures for translating, validating and using psychoeducational tests in cross-cultural assessment. *School Psychology International*, 12(1–2), 119–132. <https://doi.org/10.1177/0143034391121010>
- Brothers, A., Gabrian, M., Wahl, H. W., & Diehl, M. (2016). Future time perspective and awareness of age-related change: Examining their role in predicting psychological well-being. *Psychology and Aging*, 31(6), 605–617. <https://doi.org/10.1037/pag0000101>
- Brothers, A., Gabrian, M., Wahl, H. W., & Diehl, M. (2019). A new multidimensional questionnaire to assess awareness of age-related change (AARC). *The Gerontologist*, 59(3), e141–e151. <https://doi.org/10.1093/geront/gny006>
- Byrne, B. M. (2011). *Structural equation modeling with Mplus: Basic concepts, applications, and Programming*. Routledge. <https://doi.org/10.4324/9780203807644>
- Calik, S. G., Yilmaz, E., Balci, H., Turktemiz, H., Baser, G., & Baser, D. (2022). Relationship between covid-19 fear and ageism. *Selcuk Medical Journal*, 38(1), 23–29.
- Davis, L. L. (1992). Instrument review: Getting the most from a panel of experts. *Applied Nursing Research*, 5(4), 194–197. [https://doi.org/10.1016/S0897-1897\(05\)80008-4](https://doi.org/10.1016/S0897-1897(05)80008-4)
- Diehl, M. K., & Wahl, H. W. (2010). Awareness of age-related change: Examination of a (mostly) unexplored concept. *The Journals of Gerontology: Series B*, 65B(3), 340–350. <https://doi.org/10.1093/geronb/gbp110>
- Diehl, M., Wahl, H.-W., Barrett, A. E., Brothers, A. F., Miche, M., Montepare, J. M., Westerhof, G. J., & Wurm, S. (2014). Awareness of aging: Theoretical considerations on an emerging concept. *Developmental Review*, 34(2), 93–113. <https://doi.org/10.1016/j.dr.2014.01.001>
- Gagnier, J. J., Lai, J., Mokkink, L. B., & Terwee, C. B. (2021). COS-MIN reporting guideline for studies on measurement properties of patient-reported outcome measures. *Quality of Life Research: An International Journal of Quality of Life Aspects of Treatment Care and Rehabilitation*, 30(8), 2197–2218. <https://doi.org/10.1007/s11136-021-02822-4>
- Gürbüz, S. (2021). *AMOS ile Yapısal Eşitlik Modellemesi*. Seçkin Yayınları.

- Hair, J. F., Black, W. C., Babin, B. J., & Anderson, R. E. (2010). *Multivariate Data Analysis, seventh edition*. Prentice Hall.
- Kaspar, R., Gabrian, M., Brothers, A., Wahl, H. W., & Diehl, M. (2019). Measuring awareness of age-related change: Development of a 10-item short form for use in large-scale surveys. *The Gerontologist, 59*(3), e130–e140. <https://doi.org/10.1093/geront/gnx213>
- Kline, R. B. (2015). *Principles and practice of structural equation modeling* (fourth edition.). Guilford Publications.
- Neri, A. L., Wahl, H. W., Kaspar, R., Diehl, M., Batistoni, S. S. T., Cachioni, M., & Yassuda, M. S. (2021). Psychometric study of the awareness of age-related change (AARC) short scale translated to Portuguese, applied to Brazilian older adults. *Dementia & Neuropsychologia, 15*, 230–238. <https://doi.org/10.1590/1980-57642021dn15-020011>
- Nosrati, P., Momeni, K., & Wahl, H. W. (2022). Testing the psychometric properties of the awareness of age-related changes questionnaire in a sample of the community-dwelling elderly in Iran. *Aging Psychology, 8*(2), 133–119. <https://doi.org/10.22126/jap.2022.7125.1579>
- Sabatini, S., Silarova, B., Martyr, A., Collins, R., Ballard, C., Anstey, K. J., Kim, S., & Clare, L. (2020a). Associations of awareness of age-related change with emotional and physical well-being: A systematic review and meta-analysis. *The Gerontologist, 60*(6), e477–e490. <https://doi.org/10.1093/geront/gnz101>
- Sabatini, S., Ukoumunne, O. C., Ballard, C., Brothers, A., Kaspar, R., Collins, R., Kim, S., Corbett, A., Aarsland, D., Hampshire, A., Brooker, H., & Clare, L. (2020b). International relevance of two measures of awareness of age-related change (AARC). *BMC Geriatrics, 20*(1), 359. <https://doi.org/10.1186/s12877-020-01767-6>
- Soylu, C., & Kütük, B. (2021). SF-12 Yaşam Kalitesi Ölçeği'nin Türkçe Formunun Güvenirlik ve Geçerlik Çalışması. *Türk Psikiyatri Dergisi*. <https://doi.org/10.5080/u25700>
- Terwee, C. B., Mokkink, L. B., Knol, D. L., Ostelo, R. W. J. G., Bouter, L. M., & de Vet, H. C. W. (2012). Rating the methodological quality in systematic reviews of studies on measurement properties: A scoring system for the COSMIN checklist. *Quality of Life Research: An International Journal of Quality of Life Aspects of Treatment Care and Rehabilitation, 21*(4), 651–657. <https://doi.org/10.1007/s11136-011-9960-1>
- Ware, J. E., & Sherbourne, C. D. (1992). The MOS 36-item short-form health survey (SF-36): I. Conceptual framework and item selection. *Medical Care, 30*(6), 473–483.
- Wilton-Harding, B., & Windsor, T. D. (2022). Awareness of age-related gains and losses and their associations with psychological well-being: A longitudinal examination. *The Journals of Gerontology: Series B, 77*(4), 661–672. <https://doi.org/10.1093/geronb/gbab155>
- Zhang, W., & Wood, S. (2022). Awareness of age-related change, chronological age, subjective age and proactivity: An empirical study in China. *Frontiers in Psychiatry, 13*, 1–12.

Publisher's note Springer Nature remains neutral with regard to jurisdictional claims in published maps and institutional affiliations.

Springer Nature or its licensor (e.g. a society or other partner) holds exclusive rights to this article under a publishing agreement with the author(s) or other rightsholder(s); author self-archiving of the accepted manuscript version of this article is solely governed by the terms of such publishing agreement and applicable law.