



Atıfta Bulunmak İçin / Cite This Paper: Kilis, S. ve Uzun, A. M. (2019). "Validity and Reliability of Student Perceptions of Powerpoint Efficacy Scale", *Manas Sosyal Arařtırmalar Dergisi*, 8(3): 2501-2516.

Geliř Tarihi / Received Date: 02.01.2019

Kabul Tarihi / Accepted Date: 28.02.2019

Arařtırma Makalesi

VALIDITY AND RELIABILITY OF STUDENT PERCEPTIONS OF POWERPOINT EFFICACY SCALE

Dr. Öğr. Üyesi Selcan KİLİS

Giresun University, Faculty of Education

k1selcan@gmail.com

ORCID ID: 0000-0001-5751-2363

Arş. Gör. Dr. Ahmet Murat UZUN

Afyon Kocatepe University, Faculty of Education

auzun@aku.edu.tr

ORCID ID: 0000-0002-1852-8802

Abstract

This study aimed to adapt the student perception of PowerPoint efficacy scale into Turkish and conduct its validity and reliability tests. The scale aims to probe into student perception of multimedia in undergraduate classroom. The scale included 19-items yielded in three factors in 5-point Likert type response format. The translation was completed by eight experts and back-translation by one language expert. For testing the Turkish-translated version, 261 undergraduate students educated in undergraduate programs selected with convenience sampling were studied. The data were collected online through Google Forms in the academic year 2017-2018. Confirmatory factor analysis for validity test indicated that the model fit the data well, having acceptable or perfect fit indices, $\chi^2/df = 2.04$, RMSEA = .06, RMR = .03, SRMR = .04, TLI = .94, CFI = .94, GFI = .89, AGFI = .86, and NFI = .90. Reliability tests indicated that coefficient alpha values of three factors were found to be .87 for the first factor, .89 for the second factor, .88 for the last factor, and .94 for the whole scale which yielded high reliability. Overall, the scale was found to be valid and reliable in Turkish culture.

Keywords: Confirmatory Factor Analysis, Validity, Reliability, PowerPoint Efficacy Scale

ÖĞRENCİLERİN POWERPOINT ETKİLİLİĞE DAİR ALGILARI ÖLÇEĞİNİN GEÇERLİK VE GÜVENİRLİK ÇALIŞMASI

Öz

Bu çalışmanın amacı, öğrencilerin PowerPoint'in etkililiğine dair algıları ölçeğini Türkçe diline uyarlayarak geçerlik ve güvenirlik testlerini yapmaktır. Ölçek, üniversite lisans öğrencilerinin çoklu ortam uygulamalarına dair algılarını belirlemeyi amaçlamaktadır. Ölçek 5'li Likert türünde 3 faktörden oluşan 19 madde içermektedir. Ölçeğin Türkçe diline uyarlanması 8 uzman tarafından, orijinal diline geri çevirme işlemi ise bir dil uzmanı tarafından yapılmıştır. Geçerlik ve güvenirlik testlerini yapmak için, elverişli örnekleme yöntemiyle seçilen 261 lisans öğrencisinden veri toplanmıştır. Veriler 2017-2018 eğitim-öğretim yılında Google Form aracılığıyla çevrimiçi olarak toplanmıştır. Doğrulayıcı faktör analizi sonunda elde edilen bulgulara göre, ölçeğin uyum iyilik endeksleri $\chi^2/df = 2.04$, RMSEA = .06, RMR = .03, SRMR = .04, TLI = .94, CFI = .94, GFI = .89, AGFI = .86 ve NFI = .90 olarak bulunmuş olup, istatistiksel olarak kabul edilir veya mükemmel seviyede olduğu görülmüştür. Güvenirlik testleri sonucuna göre, ölçeğin 3 faktörüne ait iç tutarlılığını gösteren Cronbach alfa katsayıları ilk faktör için 0,87, ikinci faktör için 0,89 ve üçüncü faktör için 0,88; ölçeğin tamamı için ise

0,94 olarak bulunmuş olup, istatistiksel olarak yüksek seviyede güvenilir olduğu görülmüştür. Özetle, uyarlaması yapılan ölçek Türkçe dilinde geçerli ve güvenilir bulunmuştur.

Anahtar Kelimeler: Doğrulayıcı Faktör Analizi, Geçerlik, Güvenirlik, PowerPoint Etkililik Ölçeği

1. INTRODUCTION

PowerPoint is one of the most frequently used software in today's classrooms, which has been frequently come across in any classroom at any level of educational settings (Hopper & Waugh, 2014: 29; Moulton, Türkyay & Kosslyn, 2017: 1). In 2001, it was estimated that there were nearly 30 million slides in circulation. The rate of PowerPoint slides today may be unimaginable (Kosslyn et al., 2012: 1). Considering its prevalence, measuring its efficacy in different educational settings and then correct uses of the technology by the instructors in the classrooms appropriately have become important, since the literature includes two opposite sides of its effects on teaching and learning, referring its advantages and shortcomings.

Many scholars referred to the advantages of using PowerPoint in classroom. To Roblyer and Doering (2012: 128), PowerPoint has three dominant benefits: First, with the help of PowerPoint, teachers can organize what he or she is supposed to cover during the instruction. Presentation can amplify the speaker's message with its features of this software, if it is used correctly. Moreover, online presentation websites/tools such as Google Docs or Slideshare.net may enhance students' collaborative skills, where students can discuss on the presentations online and share their thoughts. Levasseur and Sawyer (2006: 108) reported that students believe PowerPoint slides may enhance the organization of the course. Slides can function as course notes after the instruction, being a portable and printable summary of lesson content as compared with books and e-books, etc. PowerPoint may also help note-taking during the course (Fritschi, 2008: 1). PowerPoint provides information through different modalities (i.e., visual and verbal) to learners with different needs (verbalizer and visualizer). It could make learning more enjoyable and stimulating based on the arousal theory (Levasseur & Sawyer, 2006: 14). Besides, Cognitive Theory of Multimedia Learning (CTML) postulates that learning is enhanced, when words and pictures are used together rather than words alone (Mayer, 2009: 1). Therefore, if used properly, PowerPoint enhances learning, based on CTML, as it provides information through different modalities (Atkinson & Mayer, 2004: 13).

Being an easy-to-use, simple and stable technology has led to the increase of its usage, particularly for technologically inexperienced instructors and learners as compared to other tools requiring complex technical knowledge to be used (Hertz, van Woerkum & Kerkhof,

2015: 1; Hopper & Waugh, 2014: 34). It makes information dissemination easier, which becomes important in crowded classrooms (Yilmazel-Sahin, 2009: 362). Moreover, it facilitates planning, preparing, and presenting their course materials (Levasseur & Sawyer, 2006: 108; Nouri & Shahid, 2005: 55) with saving their time.

PowerPoint has also some drawbacks and been criticized for some reasons. First, according to CTML, misuse of PowerPoint has led to violating some of the principles of CTML that could be listed as coherence, modality, redundancy, and segmenting. More specifically, the coherence principle is violated, when slides include unnecessary design elements. Modality principle of CTML may be violated, when the screen involves too much on-screen text instead of spoken text; and also redundancy may occur, if the instructor reads verbatim of the screen, which is very common in PowerPoint practices (Hill et al., 2012: 247). Segmenting principle could also be violated, if slides are presented without diving into smaller units (Atkinson & Mayer, 2004: 11). Another major criticism regarding PowerPoint is that learners passively consume the information in lectures that predominantly use PowerPoint. In other words, PowerPoint stimulates passivity placing instructors at the focal point of the action rather than actively engaging students in classroom discussion (Craig & Amernic, 2006: 154). If instructors heavily depend on the PowerPoint material in their instruction, students show fewer tendencies to ask question by interrupting their instructors (Nowaczyk et al., 1998: 378; Susskind, 2005: 213). Focusing too much on the screens (PowerPoint slides) could prevent learners focusing on what their instructor puts on emphasis during instruction (Levasseur & Sawyer, 2006: 112). It may lead learners lose their motivation or interest. Learners may miss some details of the contents covered by the instructors if they pay more attention to slides and less attention to instruction. PowerPoint could also hinder instructors' ability to use instructional methods, if they merely or heavily dependent upon presentations during lecturing, because it provides instructors ready to use contents that are read verbatim by the instructors during the instruction (Hill et al., 2010: 244; Wecker, 2012: 263). The ability and capability of the instructors could be affected negatively under this circumstance. Learning climate and learning correspondingly can also be affected negatively, because of not being able to catch up eye contact, body language, etc. during instruction (Hartnett, Römcke & Yap, 2003: 315). Furthermore, critical thinking skills, deep learning, brainstorming, interaction and communication could be hindered or affected negatively.

Taking altogether, it is evident that PowerPoint poses both advantages and disadvantages for teaching and learning, and both for teachers and for students. Although

PowerPoint is frequently criticized by the literature (e.g., Tufte, 2003) some scholars believed that the problem with PowerPoint could not wholly be attributed to the program itself (Shwom & Keller, 2003: 9 - 10). Instead, the efficacy of this presentation software depends on the appropriate usage of it, since PowerPoint is a medium and “the medium is not the entire message; any medium can be used effectively or ineffectively” (Kosslyn et al., 2012: 1). In sum, the efficacy and efficiency of the PowerPoint depend upon the effective and efficient use of it (Yilmazel-Sahin, 2009: 363). Therefore, scrutinizing how instructors’ PowerPoint practices in classroom could affect learning and deciding whether these practices contribute positively and negatively to the enhancement of learning are important steps to understand its mechanism. One way to understand the efficacy of PowerPoint is to take students’ perceptions. However, to our knowledge, there are only few measurement tools to probe into Turkish students’ perception of the efficacy of PowerPoint. In other words, there is a need for such a measurement tool to understand students’ perception of the efficacy of PowerPoint slides on presentation of the class material, its efficacy on understanding course material and classroom interactions (Nowaczyk et al., 1998: 370-381). In light of these issues, this study focuses on adapting student perceptions of PowerPoint efficacy scale and administers its validity and reliability tests to contribute to the literature in Turkish context. Understanding the efficacy or effective use of this presentation software in the eyes of the students may help instructors to revise their improper instructional practices mediated by this software.

2. METHODOLOGY

This study aims to adapt student perception of PowerPoint efficacy scale into Turkish and administers its validity and reliability testing. To this aim, the researchers referred to student perception of multimedia in the undergraduate classroom scale developed originally by Nowaczyk et al. (1998: 376).

2.1. Set of Participants

A non-random convenient sampling procedure was used to select the participants of the study. Researchers use convenient sampling, when they determine participants based on their availability, convenience, accessibility and voluntariness (Creswell, 2012: 145). The sample size was 261 undergraduate students educated at a public university in Turkey. Demographic information of the participants is provided in Table 1.

Table 1. Demographic Information of the Participants

Variable	Frequency	Percentage Value
Gender		
Female	167	64.0
Male	94	36.0
Department		
Psychological Counseling and Guidance	156	59.8
Turkish Education	71	27.2
Computer Education and Instructional Technology	34	13.0
Grade Level		
First year students	152	58.2
Second year students	76	29.1
Fourth year students	33	12.6
Age Range		
18-21	215	82.4
22-25	43	16.5
Higher than 25	3	1.1
Total	261	100.0

Of those students, 167 students (64 %) were female, while 94 (36 %) of them were male. As can be seen in Table 1, they were from three different departments; including Psychological Counseling and Guidance (n=156, ~60 %), Turkish Education (n=71, 27 %), and Computer Education and Instructional Technology (n=34, 13 %). There is again a variety in their grade level. They were mostly first year students (n=152, 58.2 %), followed by second year students (n=76, 29.1 %), and then fourth year students (n=33, 12.6 %). They were mostly at the ages of 18 to 21, followed by the range of 22 to 25. As can be inferred, their characteristics were different, which could increase the generalizability of the findings.

2.2. Original Instrument

During the adaptation of the scale, the researchers referred to student perception of multimedia scale originally developed by Nowaczyk et al. (1998: 376). The original instrument was developed to understand student perception of multimedia used in classroom. However, specifically, in this study, it was focused on taking student perception on the efficacy of PowerPoint as a multimedia tool. The scale basically has three factors and includes a total of 19 items. In the scale, students' perceptions of the PowerPoint efficacy were investigated under three sub dimensions. The first dimension of the scale concentrated on the effect of multimedia on the *presentation of the class material*, the second dimension was about the efficacy of multimedia on *understanding course materials* and the final dimension of the scale was about the effect of multimedia on *classroom interactions*. The first factor included seven items, the second factor included seven items and finally the last factor included five items. All the items were rated on a 5-point Likert type scale. The coefficient alpha values of three factors were changed in .65 to .87 (Nowaczyk et al., 1998: 375).

2.3. Translation Procedure

The procedure of translation of original scale was illustrated in Figure 1. As can be seen in Figure 1, the first step in the translation procedure is translation of scale items into Turkish. Eight experts, namely translators, completed translation of scale items separately. After eight experts translated scale items into Turkish by their own, in the second stage, all translations were compared and finalized by two translators that are more experienced in the topic and this process. When the scale items were finalized in the third stage, back-translation process started. One English language expert, who is also familiar with the topic completed back-translation of Turkish translated items into English. Then, back-translated items were compared with the original English items, whether they fit each other or not. The comparison indicated that no problem was detected in the translation of the items. After the process and translation of scale into Turkish were completed, in the last step, it was administered for its validity and reliability testing.

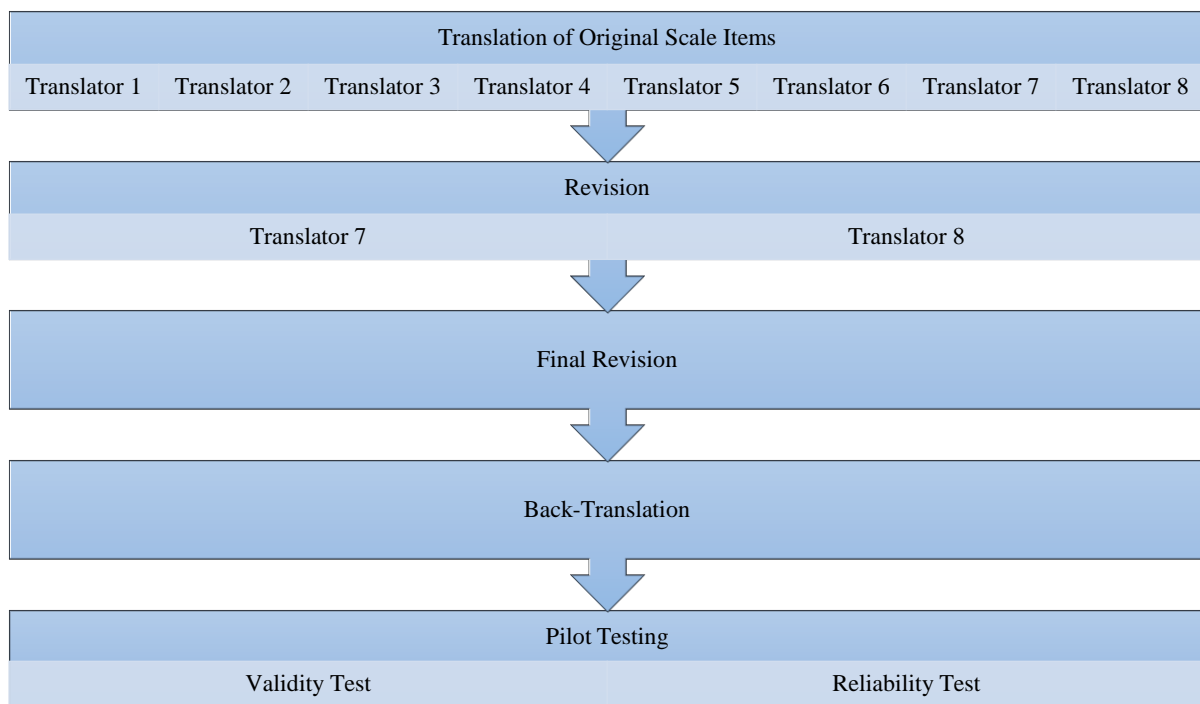

Figure 1. Translation Procedure

2.4. Data Collection

After the translation process was completed, Turkish-adapted scale items were prepared on Google Forms to collect data from students by means of the Internet. The data were collected online through Google Forms in the academic year of 2017-2018, spring semester. After data collection process finished, the process was continued with analysis of collected data, which is explained below.

2.5. Data Analysis

The collected data were entered to SPSS, version 24 to check the required assumptions and also to administer the reliability test, and then imported to AMOS version 21 to conduct confirmatory factor analysis (CFA) to administer validity test. CFA relied on a solid theoretical or empirical base and indicated how many factors there were and whether they were correlated or not (Stevens, 2009: 326). It also aimed to confirm a hypothesized factor structure with the data by forcing items to load only on a specific factor. A maximum likelihood estimation procedure was used in conducting CFA in order to examine psychometric properties of the scale and also test the strength of the factor solution put forth by the original scale. With the help of CFA, researchers could test the measurement model by testing the relationships between observed variables and the latent constructs, which are measured by these observed variables (Kline, 2015: 197).

Before the analysis, first the required assumptions were checked, whether they were met or violated. Firstly, adequate sample size was checked. According to Guilford (1954, as cited in MacCallum et al., 1999: 84), minimum sample size should be more than 200. Hair and her colleagues (Hair, Black, Babin, & Anderson, 2014: 100) declared that it should be 5 subjects per item, namely 95, since the scale includes 19 items. MacCallum and her colleagues (1999: 85) stated that it should be 10 subjects per item, namely 190. According to all different statements by different authors, since the data was collected with by participating 261 students, it could be inferred that the sample size for the study was sufficient to conduct confirmatory factor analysis. Secondly, missing cases were checked on SPSS and no missing case was found on the collected data. Thirdly, outliers were checked on SPSS with descriptive statistics and boxplots, and no outlier was detected. Fourthly, univariate and multivariate normality were checked with skewness, kurtosis, and Mardia's coefficient of multivariate normality. According to Kline (2015: 76-77) data distributions having a skewness value greater than 3 and a kurtosis value greater than 10 indicate a problem of normality. To George and Mallery (2010), skewness and kurtosis values should lay between -2 and +2. In the current study, all of the skewness and kurtosis values of the items were calculated to be not problematic lying within the threshold values. Multivariate normality was calculated by using Mardia's coefficient. Raykov and Marcoulides (2008: 81) suggested that a critical coefficient value is calculated by using the formula of " $p*(p + 2)$ ", where p is the number of the observed variables. Considering that the current scale has 19 items, this value was calculated as 399 (as measured by $19*21$). In the current study, the Mardia's coefficient value was calculated as 85.690 and this value did not exceed the critical value calculated (399) by the suggested

formula. Therefore, multivariate normality assumption has been established. In sum, the assumptions of the test were satisfied. Therefore, in the next phase, the main analyses of the CFA and reliability test were conducted, and their findings are presented in the next section.

3. RESULTS

The findings of the study were provided below in two sections; including validity results, and the reliability results. Confirmatory factor analysis was conducted based on three factors suggested by the original study. The three factors yielded in the scale were presented with F1 for the first factor, F2 for the second factor, and F3 for the third factor respectively.

3.1. Validity Results

Table 2. CFA Indices of Turkish Scale

Goodness of Fit Statistics	Perfect Value	Acceptable Value	Translated Version
χ^2/df	≤ 3	≤ 5	2.04
RMSEA	$\leq .05$	$\leq .08$.06
RMR	$\leq .05$	$\leq .08$.03
SRMR	$\leq .05$	$\leq .08$.04
TLI	$\geq .95$	$\geq .90$.94
CFI	$\geq .95$	$\geq .90$.94
GFI	$\geq .95$	$\geq .90$.89
AGFI	$\geq .90$	$\geq .85$.86
NFI	$\geq .95$	$\geq .90$.90

* $p < .01$, $N = 261$

Various fit indices could be used in order to test whether proposed model (measurement model) fit the data well or not. The perfect or acceptable values for fit indices were provided in Table 2. For the current study, the fit indices values were found to be $\chi^2/df = 2.04$, RMSEA = .06, RMR = .03, SRMR = .04, TLI = .94, CFI = .94, GFI = .89, AGFI = .86, and NFI = .90. Also as can be seen from Table 2 above, all observable fit values were within the range of the acceptable or perfect fit thresholds, which indicate that the data fit the measurement model well although only one (GFI) was not in the range but very close to the acceptable value (Çokluk, Şekercioğlu & Büyüköztürk, 2010: 271; Sümer, 2000: 60; Tabachnick & Fidell, 2013: 723-724).

Moreover, Figure 2 below indicates item-factor structure of the translated scale. From this figure, one could see the observed variables along with their relation to latent constructs. As can be seen in the figure, the highest amount of explained variance was calculated for the first factor (F1), which was named as "Presentation of the Class material with PowerPoint". In this factor, the greatest amount of variance was explained by the F1G item, showing that 61% of the variance was explained by itself. The item includes the following statement: "PowerPoint makes me more attentive". The lowest amount of explained variance belonged to F1C item with a value of 39 %, which refers to the following statement: "PowerPoint

results in more material being covered during a lecture”. The second factor (F2) was named as “Understanding the Course Material with PowerPoint”. In this factor, the F2G item, with a value of 62 %, explained the greatest amount of variance. The item refers to the following statement: “PowerPoint helps me to learn the material in a way that is comfortable”. In the second factor (F2), the lowest amounts of variances are explained by F2B and F2C, respectively. They explained almost equal variance (49 %). The item F2B refers to the statement of “PowerPoint allows me to better coordinate lecture material with text material”, whereas the F2C refers to “PowerPoint prepares me better for exams”. The last and third factor (F3) was named as “Effect of PowerPoint on Classroom Instructions”. In this factor, the greatest amount of variance was explained by the F3C item with a value of 76 %. This item includes the following statement: “PowerPoint makes me feel more of a participant in class”. On the other hand, the lowest variance was explained by the F3B with a value of 47 %. This item includes the statement of “PowerPoint facilitates class discussion”.

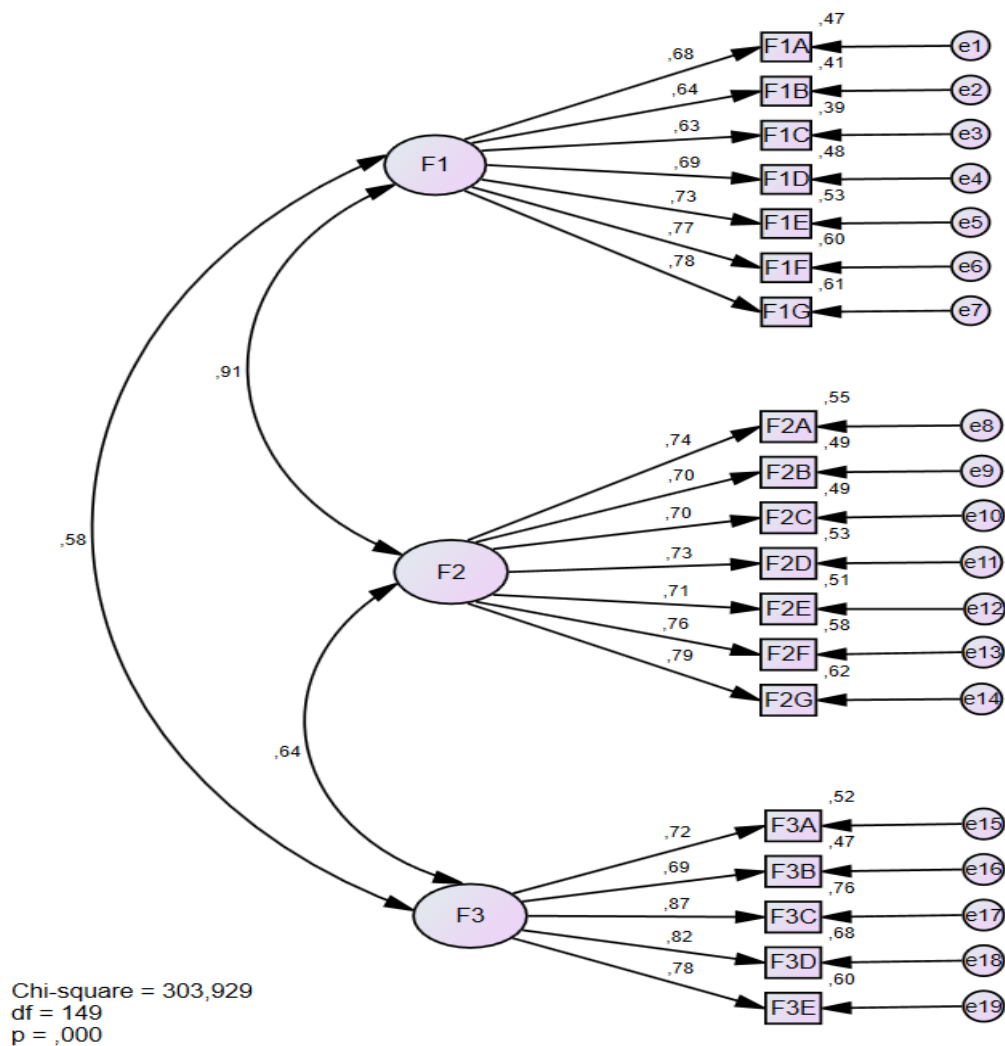

Figure 2. Item-Factor Structure of Turkish Scale

In addition to these, Figure 2 indicating item-factor structure of translated scale shows correlation among three factors. According to Figure 2, the highest correlation was observed between the first factor (F1), “Presentation of Class Material with PowerPoint”, and the second factor (F2), “Understanding Course material with PowerPoint”, with a value of .91. On the other hand, the lowest correlation was found between the first factor (F1) and the third factor (F3), “Effect of PowerPoint on Classroom Instructions”, with a value of .58.

In summary, results of the confirmatory factor analysis proved that the Turkish adapted scale was found to be valid. The findings of the reliability test of the adapted scale are provided below.

3.2. Reliability Results

Considering the reliability, internal consistency was assessed with Cronbach’s Alpha values. The results are illustrated in Table 3.

Table 3. Reliability Statistics of Three Factors of Turkish Scale

Factor	Cronbach’s Alpha
First factor (F1)	.87
Second factor (F2)	.89
Third factor (F3)	.88
Whole Scale	.94

* $p < .01$, $N = 261$

The coefficient alpha values of three factors in the original scale were changed in 0.65 to 0.87 (Nowaczyk et al., 1998: 375). In the Turkish adapted version, the coefficient alpha values of the factors of the instrument were found to be 0.87 for the first factor (Presentation of Class Material with PowerPoint), 0.89 for the second factor (Understanding Course material with PowerPoint), and 0.88 for the last factor (Effect of PowerPoint on Classroom Instructions). The reliability value of the whole scale was found as .94. Cronbach Alpha values over 0.70 indicate sufficient reliability (Hair et al. 2014: 90; Nunnally, 1978: 245). For the current study, all three factors’ alpha values were higher than 0.70 that indicates acceptable internal consistency values and therefore Turkish version of the adapted scale was reliable. In sum, when looking at validity and reliability test results, Turkish adapted version of the scale, which is provided in the Appendix, was proved to have adequate levels of validity and reliability values.

4. DISCUSSION AND CONCLUSION

This study aimed to adapt the student perception of PowerPoint efficacy scale into Turkish and administrate its validity and reliability tests. The scale was originally developed by Nowaczyk and her colleagues (1998: 376) to gauge student perception of multimedia in the undergraduate classroom. The original scale was also previously adapted by different

scholars to measure students' perception of the efficacy of PowerPoint (Burke & James, 2008: 282; Hill et al., 2012: 245). Turkish adapted version of the scale, therefore, could also be used in Turkish culture for similar purposes. With this aim, the scale items were translated into Turkish by eight experts and then back-translation was conducted with a language expert. Then, data was collected with 261 undergraduate students in a public university in Turkey, and then analyzed through SPSS version 24 and also AMOS version 21 for validity and reliability tests. The findings of statistical tests indicated that confirmatory factor analysis revealed acceptable or perfect fit indices indicating that the adapted version of the scale is valid and consisted with the measurement model put forth by the original study. The findings also indicated that coefficient alpha values for reliability of three factors and the whole scale were acceptable.

The Turkish adapted scale, which was proved its validity and reliability in this current study, could be used in Turkish context and by Turkish researchers and educators. Most of the literature on PowerPoint compared the software efficacy by testing the difference between conditions in which PowerPoint was used and those conditions in which PowerPoint was not used (c.f., Baker et al., 2018: 377-378). However, this methodological shortcoming is criticized by Moulton and colleagues (2017: 2-5), as most of the studies did not control potential biases such as presenters, audiences and so on. Therefore, in order to determine the efficacy of PowerPoint, comparing conditions, where PowerPoint is used to the conditions where it is not used could not be an appropriate method to understand its efficacy. Instead, either biases, which are confronted with media studies frequently (Moulton et al., 2017: 2-3), could be controlled or other methods should be used to determine the efficacy of PowerPoint. In other words, as mentioned before, PowerPoint is a medium and "the medium is not the entire message; any medium can be used effectively or ineffectively" (Kosslyn et al., 2012: 1). To be more precise, efficacy of PowerPoint depends on the effective use of it (Yilmazel-Sahin, 2009: 363). As Jordan and Papp (2014: 6) concluded it's not "yes" or "no" – it's "when" and "how": The problem with PowerPoint can be wholly attributed to the software itself, but the misuse of it may in fact be the primary reasons why debates on PowerPoint remain contentious. Gathering student perspective is one way to understand the efficacy of this technology. Since the scale has been originally developed in English language and there are only few measurement tools to probe into Turkish students' perception of the efficacy of PowerPoint, the current study contributes to the literature.

The current study has some limitations. First, in the measurement tool used in the current study, students' perceptions of the efficacy of PowerPoint were explored under three

sub dimensions including *presentation of class material, understanding course material and classroom discussions*. However, the scale did not deal with a specific operationalization of a learning theory. Future studies could scrutinize the effect of designing PowerPoint in accordance with a specific learning theory (e.g., CTML) on student perception of the efficacy of PowerPoint. That is, future studies could incorporate more specific items that are aligned with a sound learning theory. Second, as the measurement tool used in this study includes subjective items that are self-rated by the students, depending solely to the result of this measurement tool to determine the efficacy of PowerPoint may become misleading. Researchers may use the results obtained from students' perception of PowerPoint efficacy scale as an additional aid for the results of other measures, which could produce results that are more accurate.

To sum up, PowerPoint is one of the most frequently used software and ubiquitous tool for instructors (Baker et al., 2018: 376). The effect of PowerPoint on learning outcomes has been studied overwhelmingly, and the translated scale in this study could help to understand its effect on Turkish context. Moreover, the Turkish scale adapted into Turkish in this current study could support instructors in preparing course materials and measure its efficiency.

REFERENCES

- Atkinson, C., & Mayer, R. E. (2004). Five Ways To Reduce PowerPoint Overload. Retrieved from <https://www.Indezine.Com/Stuff/Atkinsonmaye.Pdf>.
- Baker, J. P., Goodboy, A. K., Bowman, N. D., & Wright, A. A. (2018). Does Teaching With PowerPoint Increase Students' Learning? A Meta-Analysis. *Computers & Education, 126*, 376-387.
- Burke, L. A., & James, K. E. (2008). PowerPoint-Based Lectures in Business Education: An Empirical Investigation of Student-Perceived Novelty and Effectiveness. *Business Communication Quarterly, 71*(3), 277-296.
- Craig, R. J., & Amernic, J. H. (2006). PowerPoint Presentation Technology And The Dynamics Of Teaching. *Innovative Higher Education, 31*(3), 147–160. <https://doi.org/10.1007/S10755-006-9017-5>
- Creswell, J. W. (2012). *Educational Research: Planning, Conducting, and Evaluating Quantitative And Qualitative Research* (4th Ed.). Upper Saddle River, NJ: Pearson Education.
- Çokluk, Ö., Şekercioğlu, G., & Büyüköztürk, Ş. (2010). *Sosyal Bilimler için Çok Değişkenli İstatistik [Multivariate Statistics for Social Sciences]*. Ankara, Pegem Yayıncılık.
- Fritsch, J. (2008). *Examining Pre-Service Instructors' Use of PowerPoint Based on Pre-Service Students' Perceptions: A Mixed Methods Study* (Unpublished Doctoral Dissertation). The University of Alabama at Birmingham.
- George, D., & Mallery, P. (2010). *SPSS for Windows Step By Step: A Simple Guide and Reference 18.0 Update*. Prentice Hall Press Upper Saddle River, NJ, USA.
- Guilford, J. P. (1954). *Psychometric Methods* (2th Ed). New York: Mcgraw-Hill.
- Hair, J. F., Black, W. C., Tatham, R. L., & Anderson, R. E. (2014). *Multivariate Data Analysis: Pearson New International Edition* (7th Ed.). NJ: Pearson/Prentice Hall.
- Hartnett, N., Römcke, J., & Yap, C. (2003). Recognizing the Importance of Instruction Style to Students' Performance: Some Observations from Laboratory Research—A Research Note. *Accounting Education, 12*(3), 313-331.
- Hertz, B., Van Woerkum, C., & Kerkhof, P. (2015). Why Do Scholars Use PowerPoint The Way They Do?. *Business and Professional Communication Quarterly, 78*(3), 273-291.
- Hill, A., Arford, T., Lubitow, A., & Smollin, L. M. (2012). "I'm Ambivalent about It": The Dilemmas Of PowerPoint. *Teaching Sociology, 40*(3), 242-256.

- Hopper, K. B., & Waugh, J. B. (2014). PowerPoint: An Overused Technology Deserving Of Criticism, But Indispensable. *Educational Technology*, 29-34.
- Jordan, L. A., & Papp, R. (2014). PowerPoint®: It's Not Yes Or No – It's When and How. *Research in Higher Education Journal*, 22, 1–11.
- Kline, R. B. (2015). *Principles and Practice of Structural Equation Modeling*. Guilford Publications.
- Kosslyn, S. M., & Kievit, R. A., Russell, A. G., & Shephard, J. M. (2012). PowerPoint® Presentation Flaws And Failures: A Psychological Analysis. *Frontiers in Psychology*. <https://doi.org/10.3389/fpsyg.2012.00230>
- Levasseur, D. G., & Sawyer, K. (2006). Pedagogy Meets PowerPoint: A Research Review of the Effects of Computer-Generated Slides in the Classroom. *The Review of Communication*, 6(1-2), 101-123.
- Maccallum, R. C., Widaman, K. F., Zhang, S., & Hong, S. (1999). Sample Size in Factor Analysis. *Psychological Methods*, 4(1), 84–99. <https://doi.org/10.1037/1082-989X.4.1.84>
- Mayer, R. E. (2009). *Multimedia Learning* (2 Edition). New York, USA: Cambridge University Press.
- Moulton, S. T., Türkyay, S., & Kosslyn, S. M. (2017). Does A Presentation's Medium Affect Its Message? Powerpoint, Prezi, and Oral Presentations. *Plos One*, 12(7), E0178774.
- Nouri, H., & Shahid, A. (2005). The Effect of PowerPoint Presentations on Student Learning and Attitudes. *Global Perspectives on Accounting Education*, 2, 53.
- Nowaczyk, R. H., Santos, L. T., & Patton, C. (1998). Student Perception of Multimedia in the Undergraduate Classroom. *International Journal of Instructional Media*, 25(4), 367.
- Nunnally, J. C. (1978). *Psychometric Theory*. New York: Mcgraw-Hill.
- Raykov, T., & Marcoulides, G. A. (2008). *An Introduction to Applied Multivariate Analysis*. New York: Taylor and Francis.
- Roblyer, M. D., & Doering, A. H. (2012). *Integrating Educational Technology into Teaching* (6th Ed.). Allyn & Bacon.
- Shwom, B. L., & Keller, K. P. (2003). The Great Man Has Spoken. Now What Do I Do? A Response to Edward R. Tufte's. The Cognitive Style of PowerPoint. *Communication Insight*, 1(1), 2–16.
- Stevens, J. (2009). *Applied Multivariate Statistics for the Social Sciences* (5th Ed.). NJ: Lawrence Erlbaum Associates.
- Susskind, J. E. (2005). PowerPoint's Power in the Classroom: Enhancing Students' Self-Efficacy and Attitudes. *Computers & Education*, 45(2), 203–215.
- Sümer, N. (2000). Yapısal Eşitlik Modelleri: Temel Kavramlar ve Örnek Uygulamalar [Structural Equation Modeling: Basic Concepts and Applications]. *Türk Psikoloji Yazıları*, 3(6), 74-79.
- Tufte, E. R. (2003). *The Cognitive Style of PowerPoint*. Cheshire, CT: Graphics Press.
- Wecker, C. (2012). Slide Presentations as Speech Suppressors: When and Why Learners Miss Oral Information. *Computers & Education*, 59(2), 260-273.
- Yilmazel-Sahin, Y. (2009). A Comparison of Graduate and Undergraduate Teacher Education Students' Perceptions of Their Instructors' Use Of Microsoft PowerPoint. *Technology, Pedagogy and Education*, 18(3), 361-380.

TÜRKÇE GENİŞ ÖZET

Öğretim elemanları öğrencilere sundukları öğretimsel iletilerin daha etkili ve verimli olmasını sağlamak için birçok materyalden yararlanmaktadır. Bu amaçla, en sık kullanılan araçlardan biri de PowerPoint sunum uygulamasıdır. Alan yazında PowerPoint sunum uygulamasının avantajlarının yanı sıra dezavantajlarından da bahsedilmiştir. Öte yandan bazı araştırmacılar, PowerPoint ile ilgili alan yazındaki eleştirilerin yersiz olduğunu belirtmiştir. Buna göre, asıl sorun PowerPoint sunum uygulaması ile ilgili olmayıp uygulamanın yanlış kullanılmasından kaynaklanmaktadır (Yilmazel-Sahin, 2009: 363). Bu nedenle, öğretim elemanlarının PowerPoint sunum uygulaması kullanımına ilişkin uygulamalarının ne olduğu ve bu uygulamaların öğrenci algılarına nasıl etki ettiğinin araştırılması yararlı olacaktır. Ancak, alan yazında bu konuda öğrenci algılarını belirlemeye yönelik ölçme araçları yeterli

seviyede değildir. Bu anlamda, bu çalışmanın amacı, üniversite derslerde kullanılan PowerPoint sunum uygulamasının etkililiğine dair öğrenci algıları ölçeğini Türkçe diline uyarlamak ve ölçeğin geçerlik ve güvenirlik testlerini yapmaktır. Ölçeğin orijinali Nowaczyk ve arkadaşları (1998: 376) tarafından üniversite lisans öğrencilerinin çoklu ortam uygulamalarına dair algılarını belirlemek amacıyla geliştirilmiştir. Ölçeğin orijinali İngilizce dilinde geliştirilmiştir. Ölçekte 5’li Likert türünde 19 madde yer almaktadır. Ölçek, üniversite öğrencilerinin derslerde kullanılan çoklu ortam sunumlarına dair algılarını etkileyen üç faktörden oluşmaktadır. Bu faktörler sırasıyla *ders materyallerinin sunumu*, *ders materyallerini anlama* ve *sınıf içi etkileşim* olarak belirlenmiştir. Ölçeğin orijinalinin güvenirlik katsayıları, üç faktörü için 0,65 ile 0,87 arasında bulunmuştur (Nowaczyk vd., 1998: 375). Orijinali çoklu ortam sunumlarına dair öğrenci algılarını belirlemek olan bu ölçek Türk kültürüne “derslerde kullanılan PowerPoint sunumlarının etkililiğine” dair algıları olarak uyarlanmıştır.

Ölçeğin Türkçe diline uyarlanma süreci Şekil-1’de verilmiştir. Buna göre, ölçeğin Türkçe diline uyarlanması 8 uzman tarafından yapılmıştır. Ardından bir dil uzmanı tarafından orijinal diline geri çevirme işlemi yapılmıştır. Geçerlik ve güvenirlik testlerini yapmak amacıyla veri toplama aşamasına geçilmiştir. Çalışmaya katılım; elverişli ve erişilebilir olma, uygun ve gönüllü katılımcı olma hususlarına dayanmakta olup, katılımcılar elverişli örnekleme yöntemine göre seçilmiştir. Bu bağlamda Türkiye’de bir devlet üniversitesinde eğitim gören 261 lisans öğrencisinden (167 kadın, 94 erkek) veri toplanmıştır. Katılımcıların demografik bilgileri Tablo 1’de verilmiştir. Buna göre, katılımcılar Psikolojik Danışma ve Rehberlik Bölümü (n=156, % 60), Türkçe Eğitimi (n=71, % 27) ve Bilgisayar ve Öğretim Teknolojileri Eğitimi Bölümü (n=34, %13) olmak üzere farklı disiplinlerdendir. Katılımcıların çoğunluğu birinci sınıf öğrencisi (n=152, % 58,2) iken, katılımcılar arasında ikinci sınıf öğrencileri (n=76, % 29) ve son sınıf öğrencileri de yer almaktadır (n=33, % 12,6). Katılımcıların çoğu 18-21 yaş aralığındadır.

Veriler 2017-2018 eğitim-öğretim yılı bahar yarıyılında Google Form aracılığıyla çevrimiçi olarak toplanmıştır. Çalışma boyunca etik kurallara bağlı kalınmış, katılımcıların kimlik bilgileri gizli tutulmuştur. Ölçeğin geçerliği için AMOS’ta doğrulayıcı faktör analizi (DFA) yapılmış, güvenirliğini test etmek için SPSS’te iç güvenirlik katsayıları hesaplanmıştır. Analiz aşamasına geçmeden önce, gerekli varsayımlar test edilmiştir. Bu bağlamda DFA yapabilmek için minimum örneklem büyüklüğü ile ilgili, Guilford (1954 Akt: MacCallum vd., 1999: 84) örneklem büyüklüğünün en az 200 olması gerektiğini belirtmiştir. Bu hususta Hair ve arkadaşları (2014: 100) ise ölçekte yer alan madde sayısının en az 5 katı sayıda katılımcı

olması gerektiğini savunmaktadır. MacCallum ve arkadaşları (1999: 85) ise, ölçekteki madde sayısının 10 katı sayıda katılımcının olması gerektiğini belirtmiştir. Bu görüşler doğrultusunda, 19 madde içeren PowerPoint etkililik ölçeğinin geçerlik testi için bu çalışma kapsamında 261 katılımcı ile çalışılmış olup; minimum örneklem büyüklüğü varsayımı sağlanmıştır. Ayrıca eksik veriler ve aykırı değerler de kontrol edilmiştir.

Geçerlik testi için DFA’da Türkçe ölçeğin tahmin modeli için ki-kare iyilik uyumu (χ^2) ve uyum indeks değerleri hesaplanmıştır. Elde edilen bulgulara göre, ölçeğin uyum iyilik endeksleri $\chi^2/df = 2,04$, RMSEA = 0,06, RMR = 0,03, SRMR = 0,04, TLI = 0,94, CFI = 0,94, GFI = 0,89, AGFI = 0,86 ve NFI = 0,90 olarak bulunmuş olup (Tablo-2); elde edilen değerlerin istatistiksel olarak kabul edilir veya mükemmel seviyede olduğu görülmüştür. Ekte verilen Türkçe PowerPoint etkililik ölçeğinin madde-faktör yapısı Şekil 2’de verilmiş olup, faktör yükleri (standart regresyon ağırlığı) ve faktörler arasındaki korelasyon katsayıları da detaylı olarak görülmektedir.

Ölçek faktörleri, orijinaline uyumlu bir şekilde *PowerPoint ile ders materyallerinin sunumu*, *PowerPoint ile ders materyallerini anlama* ve *PowerPoint ile sınıf içi etkileşim* olarak adlandırılmıştır. Güvenirlik testleri sonucuna göre, ölçeğin üç faktörüne ait iç tutarlılığını gösteren Cronbach alfa katsayıları ilk faktör için 0,87, ikinci faktör için 0,89 ve üçüncü faktör için 0,88; ölçeğin tamamı için ise 0,94 olarak bulunmuştur (Tablo 3). Cronbach alfa katsayısının 0,70 ve üzerindeki değerler istatistiksel olarak kabul edilen değer (Hair vd., 2014: 90) olduğu için, ölçeğin tamamı ve bütün faktörleri mükemmel seviyede güvenilir bulunmuştur.

Geçerlik ve güvenilirlik testleri sonucunda elde edilen bulgular, uyarlaması yapılan ölçeğin Türkçe dilinde geçerli ve güvenilir olduğunu göstermiştir. Dolayısıyla Türkçe PowerPoint etkililik ölçeğinin (Ek), Türk araştırmacılar ve eğitimciler tarafından üniversite öğrencilerinin öğrenme ortamlarında PowerPoint kullanılmasına dair algılarını ölçmek amacıyla kullanılması uygundur. Bununla birlikte, ölçeği kullanacak araştırmacıların ölçek ile ilgili sınırlılıkları da dikkate almalarında yarar vardır.

Appendix: The Turkish Form of the Student Perceptions of PowerPoint Efficacy Scale

	Tamamen Yanlıř	Yanlıř	Kısmen doęru	Doęru	Tamamen Doęru
POWERPOINT İLE DERS MATERYALLERİNİN SUNUMU					
Not almayı kolaylařtırır.					
Daha çok örnek verilmesini saęlar.					
Derste daha fazla konunun iřlenmesini saęlar.					
Dersin akıřı daha az bozulur.					
Derste verilen örnekleri daha açık hale getirir.					
Konuya karřı daha ilgili olmamı saęlar.					
Derse daha fazla dikkat kesilmemi saęlar.					
POWERPOINT İLE DERS MATERYALLERİNİ ANLAMA					
Derste ki kavramları anlamama yardımcı olur.					
Derste iřlenen konu ile kitaptaki konu arasında daha iyi iliřki kurmamı saęlar.					
Sınavlara daha iyi hazırlanmamı saęlar.					
Bilgilerin daha kolay hatırlanmasını saęlar.					
Ders tekrarını ve çalıřmayı daha kolay hale getirir.					
Öęrenme řeklime daha uygundur.					
Konuyu daha rahat bir řekilde öęrenmeme yardımcı olur.					
POWERPOINT İLE SINIF İÇİ ETKİLEŐİM					
Soru sormamı daha kolay hale getirir.					
Sınıf içi tartıřmaları kolaylařtırır.					
Kendimi sınıfın bir parçası gibi daha çok hissetmemi saęlar.					
Sınıftaki dięer öęrencileri daha iyi tanımama yardım eder.					
Öęretim elemanı ve öęrenciler arasında daha iyi iliřki kurulmasını saęlar.					