

The validity and reliability of the Antenatal Perceived Stress Inventory Turkish version: A methodological study

İlknur Atasever & Aslı Sis Çelik

To cite this article: İlknur Atasever & Aslı Sis Çelik (2018): The validity and reliability of the Antenatal Perceived Stress Inventory Turkish version: A methodological study, Health Care for Women International, DOI: [10.1080/07399332.2018.1469635](https://doi.org/10.1080/07399332.2018.1469635)

To link to this article: <https://doi.org/10.1080/07399332.2018.1469635>



Accepted author version posted online: 12 Jun 2018.
Published online: 01 Nov 2018.



Submit your article to this journal [↗](#)



Article views: 72



View Crossmark data [↗](#)



The validity and reliability of the Antenatal Perceived Stress Inventory Turkish version: A methodological study

İlknur Atasever^a and Aslı Sis Çelik^b

^aDepartment of Women Health and Gynecology Nursing, Nursing Faculty, Hacettepe University, Ankara, Turkey; ^bDepartment of Women Health and Gynecology Nursing, Nursing Faculty, Atatürk University, Erzurum, Turkey

ABSTRACT

The aim of the authors in this study was to adapt the Antenatal Perceived Stress Inventory developed abroad into Turkish for the evaluation of perceived stress during pregnancy. This study consisted of 350 primigravidas who attended the outpatient clinic of Nenehatun Women's Birth Hospital in Erzurum city in eastern Turkey between 10 March 2015 and 4 January 2016. The Prenatal Distress Scale and Turkish version of the Antenatal Perceived Stress Inventory were used to collect data through face-to-face interviews. The data were analyzed using SPSS for Windows and LISREL software packages. Explanatory and confirmatory factor analyses, Cronbach's alpha coefficients, split-half testing, parallel forms reliability, and test-retest methods were used to determine the validity and reliability of the Antenatal Perceived Stress Inventory. The average age of the participants was 23.51 ± 3.82 . The total score average for perceived stress on Turkish version of the Antenatal Perceived Stress Inventory was 2.28 ± 0.90 . The Cronbach's alpha coefficient of the Antenatal Perceived Stress Inventory was 0.70, the item-total point correlations were between 0.36 and 0.56, and the correlation value of the test-retest was 0.98. In the parallel forms reliability conducted to determine the equivalence of the scales, there was a statistically significant correlation between Turkish version of the Antenatal Perceived Stress Inventory and The Prenatal Distress Scale ($r = 0.689$, $p < 0.001$). The results of the explanatory factor analysis revealed that a three-factor structure, with factor loadings in the range of 0.36–0.79 explained 43.56% of the total variance. The results of the confirmatory factor analysis confirmed the validity of the three-factor structure of the scale and that the data fit of the model was acceptable. It was established that the Turkish version of Antenatal Perceived Stress Inventory was a valid and reliable measurement instrument. This scale can be used for the evaluation of perceived stress in Turkish pregnant women.

ARTICLE HISTORY

Received 16 November 2017
Accepted 23 April 2018

CONTACT Aslı Sis Çelik  aslisis@hotmail.com.tr  Department of Women Health and Gynecology Nursing, Nursing Faculty, Atatürk University, Erzurum 25240, Turkey.

Color versions of one or more of the figures in the article can be found online at www.tandfonline.com/uhcw.

© 2018 Taylor & Francis Group, LLC

Pregnancy is a physiological process, during which a number of biological changes occur (Dülgerler, Engin, & Ertem, 2005; Taşkın, 2016). The prenatal period may mark a major turning point in women's lives, with some prospective mothers perceiving pregnancy as a source of happiness and joy due to the arrival of a new family member but others perceiving pregnancy as a source of anxiety and stress (Çapık, Ejder Apay, & Sakar, 2015; Yeşilçiçek Çalık & Aktaş, 2011).

In addition to physical and hormonal changes, expectant mothers experience various psychological and social changes during pregnancy. While the mental state and experiences of the women might change the course of pregnancy, pregnancy may likewise create significant changes in the mental status of the women (Dülgerler et al., 2005; Kaplan, Bahar, & Sertbaş, 2007; Mermer, Bilge, Yücel, & Çeber, 2010). Those who are unable to sufficiently adapt to such changes experience several psychological problems for such reasons as changes in the body due to pregnancy, physical complaints, changes in family and social roles, fear of childbirth, unintended pregnancies and abortions, concerns and anxieties about the infant, and lack of social support (Eskici, Demir Akca, Atasoy, Arikan, & Harma, 2012; Yali & Lobel, 2002). If the psychological problems that emerge during pregnancy are not solved, the emotional pressures that result may continue to increase, causing stress and depression (Dülgerler et al., 2005; Kaplan et al., 2007; Ortaarık, Tekgöz, Ak, & Kaya, 2012).

The stress experienced by mother during pregnancy may affect negatively maternal, fetus, and newborn health from two different ways. The first one is that unhealthy behaviors such as smoking, use of alcohol, and not coming to perinatal follow-ups are observed in mothers experiencing stress. The second one is negative outcomes (such as preeclampsia, intrauterine growth retardation, low birth weight) to occur as a result of increasing of stress hormones (such as cortisol, catecholamines) (Obel et al., 2005; Rondo et al., 2003).

In a prospective cohort study by Szegda et al. (2018) of 1,267 Puerto Rican pregnant women between 2006 and 2011, the authors reported that an increase in perceived stress levels among pregnant women was associated with concerns about preterm birth and low birth weight.

Additionally, the stress experienced during prenatal period is closely associated with permanent health problems (cerebral palsy, hyperactivity, delays in language and mental development, chronic diseases such as hypertension, diabetes mellitus, atopik dermatit) to be experienced during childhood, adolescence, and adulthood in the long term (Graignic-Philippe, Dayan, Chokron, Jacquet, & Tordjman et al., 2014; Lobel et al., 2008; Talge, Neal, & Glover, 2007; Woods, Melville, Guo, Fan, & Gavin, 2010).

Among mothers who experienced prenatal stress, Davis and Sandman (2010) reported dysfunction in mental and motor development of children followed up at 3, 6, and 12 postnatal months. Laplante, Brunet, Schmitz, Ciampi, and King (2008) found that 12% of 2-year-old children whose mothers experienced stress during pregnancy showed a delay in their language development. Based on a meta-analysis that included 10 studies published between 1960 and 2013, Van de loo et al. (2016) reported an increase in the incidence of stertorous respiration, asthma, and other respiratory symptoms among children whose mothers experienced psychological stress during pregnancy. In the UK, MacKinnon, Kingsbury, Mahedy, Evans, and Colman (2018) observed hyperactivity and behavioral disorders among children aged 6, 9, 11, 13, and 16 years whose mothers ($n = 10,184$) were exposed to stressful events in the 18th week of pregnancy. As a result, they concluded that the risk of behavioral disorders and hyperactivity increased among children whose mothers experienced stress during pregnancy. Because of these negative effects, the stress experienced during pregnancy is a primary problem that should be addressed and cured with early diagnosis and treatment (Lobel et al., 2008; Usta & Balıkçı, 2012; Woods et al., 2010).

The first step to prevent stress during pregnancy is to determine which women are at risk. Doing so early in pregnancy may enable nurses to carry out related preventative measures and early intervention so that the negative results of stress on pregnancy, labor, and the postpartum period are either prevented or decreased (Woods et al., 2010).

In Turkey, specific measurement tools are used to detect stress and anxiety during pregnancy. These include the Beck Anxiety Inventory (Fydrich, Dowdall, & Chambless, 1992; Ulusoy, Şahin, & Erkmán, 1998), Prenatal Distress Questionnaire (Lobel, 2008; Yali & Lobel, 1999; Yüksel, Akın, & Durna, 2011), and Tilburg Pregnancy Anxiety Scale (Çapık & Pasinlioglu, 2015; Pop et al., 2011). These scales measure the level of stress, such as depression and anxiety, experienced in all trimesters of pregnancy, and they do not take account of the gravida status of the population (i.e., nulligravida, primigravida, or multigravida). According to the literature, stress levels are highest in third trimester, and previous experience of pregnancy may influence the perceived stress level of the prospective mother (Kitapçıoğlu, Yanikkerem, Sevil, & Yüksel, 2008; Ortaarık et al., 2012).

In light of this information, the aim of the authors in this study was to adapt the Antenatal Perceived Stress Inventory (APSI) developed abroad into Turkish for the evaluation of perceived stress during pregnancy. This is done by evaluating all events that are likely to be sources of stress for primigravida women in their last trimesters and examining whether or not the APSI is a valid and reliable tool for them.

Materials and methods

Study sample and population

This study was conducted in the outpatient clinic of Nenehatun Women's Birth Hospital in Erzurum city in eastern Turkey between 10 March 2015 and 4 January 2016. The population consisted of pregnant women who presented to the outpatient clinic for a prenatal examination. When adapting a measurement scale for use in another culture, the study group is required to be at least 5–10 times larger than the number of items in the scale (Gözüm & Aksayan, 2003; Karasar, 2000). In this study, the number of scale items was 12. Thus, the sample size consisted of 350 pregnant women (approximately 30 times the number of items) who presented to the outpatient clinic and agreed to participate in the study. The participants were selected by the simple random sampling method.

Inclusion criteria

All the participants fulfilled the following inclusion criteria: primary school or higher education, primigravida, 36th to 39th weeks of pregnancy according to the last menstrual period, and no adverse medical events during their pregnancies.

Data collection

The data were collected between March and August 2015 using the Prenatal Distress Scale and Turkish version of APSI through face-to-face interviews. The data were collected through the face-to-face interview method. The Prenatal Distress Scale and the Turkish version of the APSI were used to collect the data.

Data collection tools

APSI: The APSI was developed by Razurel et al. (2013) in Sweden to evaluate the perceived stress in the prenatal period by determining stress factors among women expecting their first child. The scale is applied to the pregnant women in their 36th and 39th gestational weeks (Razurel et al., 2014).

The inventory has a 5-point Likert scale and consists of 12 items and 3 subscales. The score of perceived stress during pregnancy is obtained by summing the item scores in the inventory and then dividing them into the number of items. While the lowest score to be obtained from the inventory is 1, the highest score is 5. The height of the total score obtained from the inventory indicates the highest perceived stress level of a pregnant woman (Razurel et al., 2014).

The medical and obstetric risks/fetal health subscale consists of four items.

The psychosocial changes during pregnancy' subscale consists of four items.

The prospect of childbirth subscale consists of two items. Items 2 and 6 of the inventory are not included in any factor in the original scale (Razurel et al., 2014).

According to the results of the validity and reliability analysis conducted by Razurel et al. (2014), the total Cronbach's alpha coefficient of the inventory was determined to be 0.75.

Prenatal Distress Questionnaire-NUPDQ: The questionnaire was developed by Yali and Lobel (1999) to determine the prenatal distress levels of pregnant women. The questionnaire is a 3-point Likert type, consisting of 17 items (Lobel, 2008). The Turkish validity and reliability study was conducted by Yüksel et al. (2011).

The minimum score is 0 and the maximum score is 34. The height of the total score obtained from the questionnaire indicates high prenatal-distress levels perceived by the pregnant women (Lobel, 2008; Yüksel et al., 2011).

The questionnaire consists of four subscales (Şencan, 2005). The Cronbach's alpha reliability coefficient of the questionnaire was found to be 0.85 in the study conducted by Yüksel et al. (2011).

Assessment of the data and analyses

The data were analyzed by using SPSS for Windows and LISREL packaged softwares. Language and content validity, explanatory and confirmatory factor analysis (CFA), Cronbach's alpha coefficient, split-half of the test, parallel-form reliability, and test-retest methods were used for validity and reliability analysis of the scale.

The process of translating the Turkish version of the APSI and adapting the instruments were as recommended by the World Health Organization (WHO, 2015). The scale was translated by two independent linguists who speak English and Turkish. The first translator translated the scale to Turkish, while the second translator translated the already translated scale in Turkish to English. The scale translated to Turkish was then formed by the mutual decision of both linguists. After viewing the compatibility between the original English form and the backtranslated form, the finalized Turkish form was submitted to a committee of experts, composed of thirteen people, for review. The experts were asked to evaluate each scale item's suitability and understandability according to the content validity index (CVI) on a point scale from 1 to 4 (1 point: Not suitable; 2 points:

Partly suitable, so revision of the item/statement was needed; 3 points: Rather suitable (suitable, but little adjustments were needed); 4 points: Very suitable) (Yurdugül, 2005). Eighty per cent of the scale items were expected to get 3 points or above and the items that got less than 3 points were reviewed and necessary adjustments were made. According to the percentage evaluation made in the study, the CVI of the APSI was found to be 0.96.

In order to test structural validity, exploratory factor analysis (EFA) and CFA were conducted. For the CFA, the multiple fit indexes of chi-square goodness, goodness-of-fit index (GFI), adjusted goodness-of-fit index (AGFI), comparative fit index (CFI), Standardized Root Mean Square Residuals (SRMR), and Root Mean Square Error of Approximation (RMSEA) were analyzed.

Ethical considerations

The study was approved (2015/2) by the Ataturk University Institute of Health Sciences ethics board. For the Turkish adaptation of the APSI, written permission was received by e-mail from Chantal Razurel, who developed the original inventory. Written permission for adapting the Prenatal Distress Scale into Turkish was also obtained from the authors. In addition, written permission from the relevant hospital to collect the data was obtained. All the participants in the study provided informed consent. This study conformed to the tenets of the Declaration of Helsinki.

Statistical analysis

The data were analyzed using SPSS for Windows and LISREL software packages. Explanatory and confirmatory factor analyses, Cronbach's alpha coefficients, split-half testing, parallel forms reliability, and test-retest methods were used to determine the validity and reliability of the scales.

Results

The average age of the participants was 23.51 ± 3.82 . 33.7% of pregnant are middle school graduates. It was determined that 99.1% of pregnancies were willingly pregnant, 29.7% of them were in the 36th gestational week, 25.1% in the 37th week, 24% in the 38th week and 21.1% in the 39th gestational week. The total score average for perceived stress on Turkish version of the APSI was 2.28 ± 0.90 . The average scores for the sub-dimensions of "medical and obstetric risks/death," "psychosocial changes during pregnancy," and "birth expectation" were 2.29 ± 1.26 , 2.13 ± 1.27 , and 2.49 ± 1.31 , respectively. Based on these scores, the participants in the present study can be considered to have experienced a medium level of stress.

Table 1. Cronbach's alpha coefficient for Antenatal Perceived Stress Inventory.

Item no.	Arithmetic mean	Standard deviation	Mean of scale if item is omitted	Variance of scale if item is omitted	Corrected item-total score correlation	Cronbach's alpha coefficient if item is omitted
1	3.27	1.445	34.33	65.600	.346	.659
2	3.13	1.367	34.47	65.591	.376	.656
3	2.04	1.536	35.56	68.341	.200	.681
4	3.25	1.663	34.35	64.335	.326	.662
5	3.36	1.444	34.25	66.933	.307	.668
6	3.70	1.509	33.91	64.459	.374	.655
7	2.05	1.521	35.56	65.489	.324	.662
8	3.36	1.622	34.25	62.374	.421	.646
9	2.85	1.647	34.75	63.845	.351	.658
10	2.83	1.584	34.77	64.099	.362	.656
11	3.79	1.594	33.82	68.047	.308	.682
12	3.96	1.490	33.65	67.118	.364	.671
	Arithmetic mean	Variance	Standard deviation	Number of items	Cronbach's alpha	Range
	37.61	75.786	8.706	12	.701	44.00

Results concerning the reliability of Antenatal Perceived Stress Inventory

Internal consistency

Table 1 shows that the APSI had no problematic item, and the Cronbach's alpha coefficient of the scale was 0.70. The required range for the scale is 60, but it was observed that the calculated range was 44.

All the correlation values of the APSI with its subscales were significant at a significance level of $p < 0.001$, and the Cronbach's alpha values ranged from 0.71 to 0.73.

The item-total score correlations in the APSI were significant at $p < 0.01$ (Table 2). The correlation values were at the requested level for the item analysis.

Time invariance (test-retest)

Test-retest was carried out to determine the time invariance of the inventory, and the Pearson product moment results were examined (Table 3). The correlation value of the relationship between the first and second measurement results was $r = 0.984$, which was significant at $p < 0.001$ (Table 3). This result showed that the first and second measurement results of the inventory administered at a 2-week interval were similar.

Parallel-form reliability

For the parallel-form reliability, the relationship between the APSI and the Prenatal Distress Questionnaire was analyzed, and the Pearson product moment correlation analysis was conducted. The correlation value of the relationship between the two scales was $r = 0.91$, which was significant at a significance level of $p < 0.001$. This result indicated that there was a relationship between the APSI and the Prenatal Distress Questionnaire.

Table 2. Item-total score correlation of the Antenatal Perceived Stress Inventory.

Items	<i>r</i>	<i>p</i>
Item 1	.488**	.000
Item 2	.507**	.000
Item 3	.367**	.000
Item 4	.491**	.000
Item 5	.435**	.000
Item 6	.518**	.000
Item 7	.476**	.000
Item 8	.568**	.000
Item 9	.511**	.000
Item 10	.515**	.000
Item 11	.370**	.000
Item 12	.420**	.000

Table 3. Correlation between Antenatal Perceived Stress Inventory's first and second measurement scores.

Measurements	Mean \pm SD	<i>r</i>	<i>p</i>
First measurement	3.13 \pm 0.72	.984	.000
Second measurement	3.37 \pm 0.63		

Results concerning the validity of the Antenatal Perceived Stress Inventory

Construct validity

Explanatory and confirmatory factor analyses were performed to reveal the factor structure of the APSI.

Explanatory factor analysis

To determine whether the factor analysis was performed for the data, the Kaiser–Meyer–Olkin (KMO) test and the Bartlett's Test of Sphericity were carried out. Table 4 illustrates these results.

Table 4 shows that the KMO coefficient was observed to be 0.731. It was understood from this result that the sample size was proper for the factor analysis. As can be seen from Table 4, the chi-square value related to the Bartlett's test was significant, with a significance level of $p < 0.05$. This result showed that the data were applicable for factor analysis.

As shown in Table 5, after the factor analysis of the 12-item APSI, a three-factor structure appeared, explaining 43.56% of the total variance and having an eigenvalue above 1.00.

In the graphic obtained from the Scree Plot test, the first sudden change with an eigenvalue above 1.00 occurred in the third factor, and it was decided that this was a three-factor scale based on this result.

As a result of the factor analysis, the factor loadings were found to be between 0.36 and 0.79. These results indicated that the construct validity of the inventory was suitable. Table 6 shows the information regarding which items are involved in which factors.

Table 4. KMO and Bartlett's test results.

Tests	Results	<i>p</i>
KMO	0.731	
Bartlett's test	$\chi^2 = 458.249 \pm 66$	0.000

Table 5. Factor analysis of the Antenatal Perceived Stress Inventory.

Components	Initial eigenvalues			Sum of squares of loads			Sum of squares of loads after rotation		
	Total	Variance %	Cumulative %	Total	Variance %	Cumulative %	Total	Variance %	Cumulative %
1	2.742	22.849	22.849	2.742	22.849	22.849	1.876	15.634	15.634
2	1.330	11.083	33.932	1.330	11.083	33.932	1.766	14.713	30.347
3	1.156	9.635	43.567	1.156	9.635	43.567	1.586	13.220	43.567
4	.999	8.323	51.890						
5	.916	7.636	59.525						
6	.875	7.292	66.818						
7	.855	7.125	73.943						
8	.763	6.359	80.302						
9	.723	6.023	86.325						
10	.632	5.266	91.590						
11	.541	4.506	96.097						
12	.468	3.903	100.000						

The first factor in [Table 6](#) explains 15.63% of total variance; the second factor explains 14.71%; and the third factor explains 13.22%. All factors explain 43.56% of the total variance.

Confirmatory factor analyses

In this section of the study, the suitability of the three-factor structure appearing as a result of the explanatory factor analysis and the Scree Plot test was tested.

CFA was performed to determine whether the three-factor structure of the scale would be confirmed. According to the results of the CFA, the following values were found: $\chi^2 = 1186.35$; $N = 54$; $sd = 480$ and $p = 0.000$. $\chi^2/sd = 2.47$ and is smaller than the acceptable reference value of ≤ 5 . The following values were also found: $RMSEA = 0.080$, $SRMR = 0.07$, $NFI = 1.00$, $CFI = 1.00$, $GFI = 0.96$ and $AGFI = 0.92$. [Figure 1](#) shows the first-level CFA results.

Discussion

The reliability of the Turkish version of the Turkish version of the APSI was evaluated by descriptive factor analysis, Cronbach's α internal consistency coefficients, item-total correlations, test-retest analysis, and parallel forms reliability.

Cronbach's alpha coefficient is calculated to determine the internal consistency of Likert-type scales. In the literature, it is stated that when Cronbach's alpha coefficient is $0.60 < \alpha < 0.80$, the scale is considerably

Table 6. Distribution of items of the Antenatal Perceived Stress Inventory based on factor.

Item no.	Items of Antenatal Perceived Stress Inventory	Factors		
		1	2	3
8	I feel stressed about my baby's health.	.758		
9	I feel stressed about the screening tests for genetic disorders such as down syndrome.	.790		
10	I feel stressed about having an ultrasound scan.	.714		
1	I feel stressed about the health problems I may encounter during my pregnancy.		.360	
2	I feel stressed about things I was previously doing but not during my pregnancy (smoking, use of alcohol, going out, travel, sports, etc.).		.507	
3	I feel stressed about the changes to occur in my weight during pregnancy.		.547	
5	I feel stressed about my mental condition and oversensitivity during my pregnancy		.641	
7	I feel stressed about my relations with my husband during my pregnancy.		.626	
11	I feel stressed about whether or not I am going to be put under epidural anesthesia			.691
12	I feel stressed about whether or not I would feel pain if episiotomy was administered.			.665
4	I feel stressed about feeling exhausted during my pregnancy.			.493
6	I feel stressed about not knowing when I would give birth.			.363
Explained variance %		15.63	14.71	13.22
Total variance explained %		15.63	30.34	43.56

reliable; and when it is $0.80 < \alpha < 1.00$, the scale is reliable at a high rate (Akgül, 2005). The Cronbach's alpha coefficient of the APSI was 0.70, and coefficients for subscales ranged from 0.71 to 0.73. As the Cronbach's alpha coefficients of the overall scale and its subscales were in the range of $0.60 < \alpha < .80$, the scale can be considered to be reliable. The Cronbach's alpha coefficient of the original scale was 0.75 (Razurel et al., 2014). Therefore, the coefficients of the scales were similar.

Another internal consistency measure is the item total-score correlation. When this coefficient is low, it is decided that the items of the scale are not sufficiently reliable (Akgül, 2005). In the literature, it is stated that the item-total score correlation of an item is required to be a minimum 0.20 (Öner, 2009). In this study, the item-total score correlations varied between 0.36 and 0.56, and the item-total score correlation of all items was at a sufficient level. It was found that all the item-total score correlations of the scale items were significant at a significance level of $p < 0.01$. These results indicated that the 12-item APSI had no problematic item.

Test-retest was carried out to evaluate the scale's time invariance. The literature states that at least 30 individuals need to be reached for test-retest (Tavşancıl, 2002). In this study, the scale was administered to the sample group of 70 people and was administered for the second time 2 weeks later. There was a strong statistically significant correlation between the results of the first and second measurements of Turkish version of the APSI ($r = 0.984$, $p < 0.001$). Thus, a test-retest of the original scale was not performed.

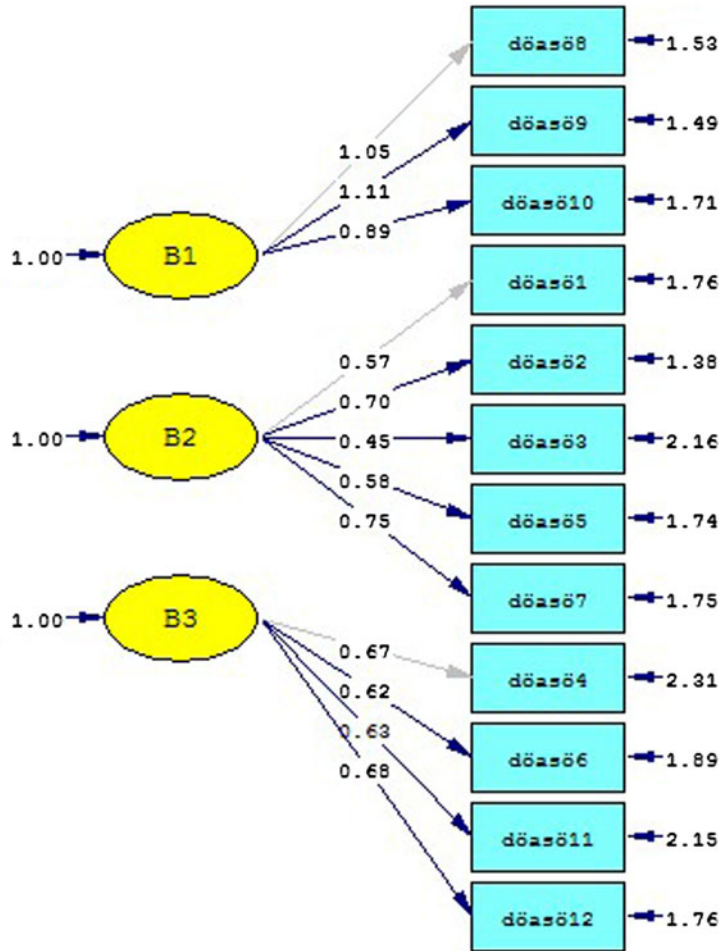

Chi-Square=186.35, df=54, P-value=0.00000, RMSEA= 0.080

Figure 1. CFA graphic of the Antenatal Perceived Stress Inventory.

This result indicated that the first and second measurement results of the scale were similar and proved that the scale had the time invariance.

If there is a reference scale developed previously in scale adaptation studies for the same purpose in the related field, parallel-form reliability can be determined between this reference scale and the adapted scale.

With respect to determining the parallel-form reliability, another assessment instrument with the same qualities is administered on the same individuals and at the same time, and the correlation is sought between the scores obtained from two assessment instruments (Akgül, 2005; Şencan, 2005).

The obtained correlation coefficient is the equivalence coefficient, indicating the consistency of the responses. The coefficient is required to be at least 0.70 (Şencan, 2005).

Parallel forms reliability was used as a measure of the reliability of Turkish version of the APSI. The reliability and validity of the Turkish

version of the Prenatal Distress Scale have been demonstrated previously, and this scale was used for the parallel forms reliability (Yüksel et al., 2011). The correlation between Turkish version of the APSI and Prenatal Distress Scale was $r=0.91$, with a significant correlation between the two scales ($p < 0.001$). Razurel et al. (2014) assessed the convergent validity of APSI by comparing the results obtained with those obtained using the Perceived Stress Scale (PSS) (Cohen, Kamarck, & Mermelstein, 1983). This analysis revealed a significant correlation between perceived stress measured with the APSI and PSS ($r = .421, p < 0.001$) (Razurel et al., 2014).

The results obtained from the analyses performed for determining reliability of the scale indicated that the APSI had a high reliability.

In construct validity, the factors measured by the scale are analyzed, or the relationship between the scale whose validity is researched and other scales and measures is sought (Gözüm & Aksayan, 2003). To test the structural validity of the APSI translated into Turkish, explanatory factor analysis and CFA were performed.

Before performing the factor analysis, KMO analysis was performed to determine the sufficiency for the sample's factor analysis, and Bartlett's Test of Sphericity was carried out to determine the suitability of the samples for the factor analysis (Şencan, 2005).

According to previous research, for data to be suited to factor analysis, a KMO value greater than 0.60 was required (Büyüköztürk, 2007). In the original scale, a KMO value of 0.67 was reported to be statistically significant using Bartlett's test (Razurel et al., 2014). In this study, the KMO coefficient was 0.73. As the two coefficients were close to each other, the sample size was sufficient for factor analysis.

According to the result of Bartlett's test, $\chi^2 = 458.249$ and $p = 0.000$ was found. The fact that the result of this test was significant revealed that the sample size and correlation matrix were suitable (Büyüköztürk, 2007; Şencan, 2005). Moreover, this result showed that the data were suitable for factor analysis.

For the explanatory factor analysis, the data were analyzed by using the principal components method and the varimax vertical rotation method, as in the original scale (Razurel et al., 2014).

A three-factor structure, with an eigen value greater than 1.00 explained 58.53% of the total variance in the original scale (Razurel et al., 2014). In the present study, the factor analysis of the APSI revealed a three-factor structure, with an eigenvalue above 1.00 explaining 43.56% of the total variance.

It is reported in the literature that for factor analysis, the percentage of factor loadings to explain total variance is required to be 0.40 and above (Kline, 1994; Şencan, 2005). The fact that a scale has a high rate of variance explained signifies that the scale has a strong factor structure.

In the factor analysis, the Scree Plot test is used to find out the number of factors in the scale. By using the graphic method in the Scree Plot test, the factors having eigenvalues above 1 are analyzed. The literature suggests selecting the factors until the first sudden change in the graphic is obtained as a result of this test and the curve of the graphic (Kline, 1994).

The graphic obtained from the scree plot test shows the eigen values obtained in the factor analysis. Thus, in accordance with the original scale, the scale in the present study had a three-factor structure.

According to the literature, the factor loadings are required to be 0.30 and above as a result of the factor analysis (Büyüköztürk, 2007). Razurel et al. (2014) reported factor loadings of items ranging from 0.57 to 0.82 (Razurel et al., 2014). In the current study, the factor loadings of the items ranged from 0.36 to 0.79.

To determine which items constitute the three factors in the APSI, the varimax rotation method and the factor-loading matrix were examined.

According to the result of the factor-loading matrix, despite some of the items in the original scale being replaced among the factors, when the content of the items in the factors was examined, it was observed that making any change in the naming of the factors was unnecessary, and the names of the factors were left as in the original scale.

When compared with the literature data, the results of the explanatory factor analysis, the item factor loads, and the variance explained could be asserted to be at sufficient levels.

After the explanatory factor analysis, the CFA was performed to determine whether the factor structure of the scale's original version would be confirmed. The CFA is a method of examination used to fit indices that indicate the fit level between the data and the construct (Erkorkmaz, Etikan, Demir, Özdamar, & Sanisoğlu, 2013; Gözüm & Aksayan, 2003; Şencan, 2005).

According to the results of the CFA, the following values were found: $\chi^2 = 1186.35$; $N = 54$; $sd = 480$; and $p = 0.000$. χ^2 results test the fit between the data and the model and indicate that the data are consistent with the model. $\chi^2/sd = 2.47$ and is smaller than the acceptable reference value of ≤ 5 . This result also indicates that the data were consistent with the model. RMSEA, which is another indicator of the model-data fit, was found to be equal to the acceptable reference value of 0.080 (Erkorkmaz et al., 2013).

In the literature, the fact that RMSEA and SRMR values are close to 0 and are smaller than 0.05 shows the perfection of the model-data fit; whereas, small values of 0.08 and below are indicated to be acceptable for the model and data fit (Şeşen & Meydan, 2011; Şimşek, 2007). It is reported in the literature that values of 0.90 and above for GFI and AGFI are sufficient for the model-data fit, whereas values of 0.95 and above for

CFI and NFI show the perfection of the model-data fit (Marsh, Balla, & McDonald, 1988).

The following values were also found: RMSEA = 0.080, SRMR = 0.07, NFI = 1.00, CFI = 1.00, GFI = 0.96 and AGFI = 0.92. When examining the values obtained as a result of CFA, it was observed that they were at a good fit level. In other words, it could be asserted that the three-factor model was suitable, and the construct validity of the scale was provided.

These values were found in the original scale as $\chi^2/sd = 1.29$, GFI = 0.935, CFI = 0.954, AGFI = 0.901, and RMSEA = 0.44 (Razurel et al., 2014).

The data obtained as a result of CFA revealed that the APSI is a three-factor model, as in the original scale, and that the construct validity of the scale was provided.

A scale developed in a particular culture and language is subject to culture-specific conceptualization and sampling. When adapted to different cultures and communities, such scales may be able to measure many global concepts and provide opportunities for cross-cultural comparisons and discussions. In addition, while making cross-cultural comparisons, similarities and differences in the two scales applied to individuals with similar characteristics in both cultures can be compared and discussed (Aksayan & Gözüm, 2002; Gözüm & Aksayan, 2003). The fact that the prenatal PSS shares many similar traits in terms of psychometric properties with the APSI indicates that there are no major differences in the factors affecting perceived stress in both communities. To enable similar interpretations, the validity and reliability of the scale could be studied in different communities. The population in the present study consisted of primigravidas who attended a prenatal checkup at an outpatient clinic of Nenehatun Women's Birth Hospital in Erzurum city in eastern Turkey. The application of the APSI to other populations, including multiparous women, would be useful to evaluate both cultural conventions and parity among perceived stress levels.

Conclusion

The analysis of the reliability and validity of the Turkish version of the APSI demonstrated that it showed good comprehensibility, internal consistency, and validity. The use of a measurement instrument, such as the APSI, would be very useful for nurses to assess perceived stress associated with prenatal and antenatal periods and develop care plans to reinforce positive mental health. Enactment of such plans at an early stage of a pregnancy could enable health care providers to carry out related preventative

measures and early interventions to prevent or decrease the negative effects of stress on pregnancy, labor, and the postpartum period.

Notes

- This research was prepared from master thesis which accepted by Atatürk University Health Sciences Institute in 2016.
- Abstract of manuscript was presented as an oral presentation at 18th ISPG congress on 12–14 May 2016, Malaga/Spain.

Ethical approval

We confirm that we have ethical council decision from Ethics Committee of Atatürk University, Institute of Health Sciences. We consider ethical rules.

Acknowledgments

The authors thank all the women for their participation. The authors also thank Assoc. Prof. Başaran Gençdoğan for help with statistical analyses and expert group for expert's reviews.

Conflict of interest

There is no conflict of interest between any person or any institution.

Author contribution

İlknur ATASEVER taken permission from Razurel C. and Yüksel F. and collected the data and wrote the manuscript. Aslı SİS ÇELİK did statistical analysis, interpretation of data, and wrote the manuscript.

References

- Akgül, A. (2005). *Tıbbi Araştırmalarda İstatistiksel Analiz Teknikleri SPSS uygulamaları* [Statistical analysis techniques in medical research SPSS applications]. (3rd ed.). Ankara: Emek Ofset Ltd. Şti.
- Aksayan, S., & Gözümlü, S. (2002). Kültürlerarası ölçek uyarlaması için rehber I: Ölçek uyarlama aşamaları ve dil uyarlaması [A guide for transcultural adaptation of the scale: Scale adaptation steps and language adaptation]. *Journal of Research in Nursing*, 4, 9–14.
- Büyüköztürk, Ş. (2007). *Veri analizi el kitabı* [Data analysis manual] (8th ed., pp. 167–182). Ankara: Pegem Ak.
- Çapık, A., Ejder Apay, S., & Sakar, T. (2015). Gebelerde Distres Düzeyinin Belirlenmesi [Determination of the level of distress in pregnant women]. *Anadolu Hemşirelik Ve Sağlık Bilimleri Dergisi*, 18, 196–203.
- Çapık, A., & Pasinlioglu, T. (2015). Validity and reliability study of the Tilburg Pregnancy Distress Scale into Turkish. *Journal of Psychiatric and Mental Health Nursing*, 22(4), 260–269.

- Cohen, S., Kamarck, T., & Mermelstein, R. (1983). A global measure of perceived stress. *Journal of Health and Social Behavior*, 24, 385–396.
- Davis, E. P., & Sandman, C. A. (2010). The timing of prenatal exposure to maternal cortisol and psychosocial stress is associated with human infant cognitive development. *Child Development*, 81(1), 131–148.
- Dülgerler, Ş., Engin, E., & Ertem, G. (2005). Gebelerin ruhsal belirti dağılımlarının incelenmesi [Investigation of pregnant's psychiatric symptoms]. *Journal of Ege University Nursing Faculty*, 21, 115–126.
- Erkorkmaz, Ü., Etikan, İ., Demir, O., Özdamar, K., & Sanisoğlu, S. Y. (2013). Confirmatory factor analysis and fit indices: Review. *Türkiye Klinikleri Journal of Medical Sciences*, 33(1), 210–223.
- Eskici, L., Demir Akca, A. S., Atasoy, N., Arıkan, İ., & Harma, M. (2012). Gebelerde Depresyon ve Anksiyete Bozukluğunun Obstetrik Sonuçları ve Yenidoğan Üzerine Etkileri [Examination of the possible effects of depression and anxiety disorders in pregnant women on obstetric outcomes and newborn]. *Anatolian Journal of Clinical Investigation*, 6, 10–16.
- Fydrich, T., Dowdall, D., & Chambless, D. L. (1992). Reliability and validity of the beck anxiety inventory. *Journal of Anxiety Disorders*, 6(1), 55–61.
- Gözüm, S., & Aksayan, S. (2003). Kültürlerarası ölçek uyarlaması için rehber II: Psikometrik özellikler ve kültürlerarası karşılaştırma [A guide for transcultural adaptation of the scale II: Psychometric characteristics and cross-cultural comparison]. *HEAD*, 5, 3–14.
- Graignic-Philippe, R., Dayan, J., Chokron, S., Jacquet, A. Y., & Tordjman, S. (2014). Effects of prenatal stress on fetal and child development: A critical literature review. *Neuroscience & Biobehavioral Reviews*, 43, 137–162.
- Kaplan, S., Bahar, A., & Sertbaş, G. (2007). Gebelerde Doğum Öncesi Ve Doğum Sonrası Dönemlerde Durumluk Kaygı Düzeylerinin İncelenmesi [Evaluation of the anxiety levels of pregnant women at prenatal and postnatal period] *Journal of Anatolia Nursing and Health Sciences*, 10, 113–121.
- Karasar, N. (2000). *Bilimsel Araştırma Yöntemi: Kavramlar, İlkeler, Teknikler* [Scientific research method: Concepts, principles, techniques]. (10th ed.). Ankara: Nobel Basım Evi.
- Kitapçıoğlu, G., Yanıkkerem, E., Sevil, Ü., & Yüksel, D. (2008). Gebelerde doğum ve postpartum döneme ilişkin endişeler; bir ölçek geliştirme ve validasyon çalışması [Fear of childbirth and the postpartum period: A scale development and validation study]. *Adnan Menderes Üniversitesi Tıp Fakültesi Dergisi*, 9, 47–54.
- Kline, P. (1994). *An easy guide to factor analysis*. London: Routledge.
- Laplante, D. P., Brunet, A., Schmitz, N., Ciampi, A., & King, S. (2008). Project ice storm: Prenatal maternal stress affects cognitive and linguistic functioning in 5 1/2-year-old children. *Journal of the American Academy of Child and Adolescent Psychiatry*, 47(9), 1063–1072.
- Lobel, M. (2008). The Stony Brook pregnancy project: Revised prenatal distress questionnaire (NUPDQ): 17-Item Version, NUPDQ2.DOC, 06/25/96.
- Lobel, M., Cannella, D. L., Graham, J. E., DeVincent, C., Schneider, J., & Meyer, B. A. (2008). Pregnancy-specific stress, prenatal health behaviors, and birth outcomes. *Health Psychology*, 27(5), 604–615.
- MacKinnon, N., Kingsbury, M., Mahedy, L., Evans, J., & Colman, I. (2018). The association between prenatal stress and externalizing symptoms in childhood: Evidence from the Avon Longitudinal Study of Parents and Children. *Biological Psychiatry*, 83(2), 100–108.

- Marsh, H. W., Balla, J. R., & McDonald, R. P. (1988). Goodness-of-fit indexes in confirmatory factor analysis: The effect of sample size. *Psychological Bulletin*, 103(3), 391–410.
- Mermer, G., Bilge, A., Yücel, U., & Çeber, E. (2010). Gebelik ve doğum sonrası dönemde sosyal destek algısı düzeylerinin incelenmesi [Evaluation of perceived social support levels in pregnancy and postpartum periods]. *Journal of Psychiatric Nursing*, 1, 71–76.
- Obel, C., Hedegaard, M., Henriksen, T. B., Secher, N. J., Olsen, J., & Levine, S. (2005). Stress and salivary cortisol during pregnancy. *Psychoneuroendocrinology*, 30(7), 647–656.
- Ortaarık, E., Tekgöz, İ., Ak, M., & Kaya, E. (2012). İkinci trimestir gebelerde depresyon ve anksiyete bozukluğu ile ilişkili faktörlerin değerlendirilmesi [Evaluation of the factors associated with depression and anxiety disorder in the pregnant at second trimester]. *Journal of İnönü University, Health Science*, 1, 16–20.
- Öner, N. (2009). *Türkiye’de Kullanılan Psikolojik Testler, Bir Başvuru Kaynağı* [Psychological tests used in Turkey, a reference source]. (3rd ed.). İstanbul: Boğaziçi Matbaası.
- Pop, V. J. M., Pommer, A. M., Pop-Purceleanu, M., Wijnen, H. A. A., Bergink, V., & Pouwer, F. (2011). Development of the Tilburg Pregnancy Distress Scale: The TPDS. *BMC Pregnancy and Childbirth*, 11, 80–87.
- Razurel, C., Kaiser, B., Dupuis, M., Antonietti, J. P., Citherlet, C., Epiney, M., & Sellenet, C. (2014). Validation of the antenatal perceived stress inventory. *Journal of Health Psychology*, 19(4), 471–481.
- Rondo, P. H. C., Ferreira, R. F., Nogueira, F., Ribeiro, M. C. N., Lobert, H., & Artes, R. (2003). Maternal psychological stress and distress as predictors of low birth weight, prematurity and intrauterine growth retardation. *European Journal of Clinical Nutrition*, 57(2), 266–272.
- Szegda, K., Bertone-Johnson, E., R., Pekow, P., Powers, S., Markenson, G., Dole, N., & Chasan-Taber, L. (2018). Prenatal perceived stress and adverse birth outcomes among puerto rican women. *Journal of Women’s Health*, 27(5), 699–708.
- Şencan, H. (2005). *Sosyal ve Davranışsal Ölçümlerde Güvenilirlik ve Geçerlilik* [Reliability and validity of the social and behavioral measurements]. (1st ed.). Ankara: Seçkin Yayıncılık.
- Şeşen, H., & Meydan, H. (2011). *Yapısal Eşitlik Modellemesi AMOS uygulaması* [Application of structural equation modeling AMOS]. (1st ed.). Ankara: Detay Yayıncılık.
- Şimşek, Ö. F. (2007). *Yapısal Eşitlik Modellemesine Giriş: Temel İlkeler ve LISREL Uygulamaları* [Introduction to structural equation modeling: Basic principles and LISREL applications]. (1st ed.). Ankara: Ekinoks Basın Yayın Dağıtım Ltd Sti.
- Talge, N. M., Neal, C., & Glover, V. (2007). Antenatal maternal stress and long-term effects on child neurodevelopment: How and why? *Journal of Child Psychology and Psychiatry*, 48(3–4), 245–261.
- Taşkın, L. (2016). *Doğum ve Kadın Sağlığı Hemşireliği* [Birth and women’s health nursing], 13. Baskı. Ankara: Özyurt Matbaacılık, 259–265.
- Tavşancıl, E. (2002). *Tutumların ölçülmesi ve SPSS ile veri analizi* [Measurement of attitudes and data analysis with SPSS]. (2nd ed.). Ankara: Nobel Yayın Dağıtım.
- Ulusoy, M., Şahin, N., & Erkmán, H. (1998). Turkish version of the beck anxiety inventory: Psychometric properties. *Journal of Cognitive Psychotherapy – An International Quarterly*, 12, 28–35.
- Usta, M. G., & Balıkçı, A. (2012). Prenatal Stresin Nörogelişimsel Etkileri [Neuro developmental outcomes of prenatal stress]. *Current Approaches in Psychiatry*, 4, 99–111.

- Van De Loo, K. F., Van Gelder, M. M., Roukema, J., Roeleveld, N., Merkus, P. J., & Verhaak, C. M. (2016). Prenatal maternal psychological stress and childhood asthma and wheezing: A meta-analysis. *European Respiratory Journal*, 47(1), 133–146.
- WHO. (2015). *Process of translation and adaptation of instruments*. Retrieved from http://www.who.int/substance_abuse/research_tools/translation/en/
- Woods, S. M., Melville, J. L., Guo, Y., Fan, M. Y., & Gavin, A. (2010). Psychosocial stress during pregnancy. *American Journal of Obstetrics and Gynecology*, 202(1), 61.e1–67.
- Yali, A. M., & Lobel, M. (1999). Coping and distress in pregnancy: An investigation of medically high risk women. *Journal of Psychosomatic Obstetrics and Gynaecology*, 20(1), 39–52.
- Yali, A. M., & Lobel, M. (2002). Stress-resistance resources and coping in pregnancy. *Anxiety, Stress & Coping*, 15(3), 289–309.
- Yeşilçiçek Çalık, K., & Aktaş, S. (2011). Gebelikte depresyon: Sıklık, risk faktörleri ve tedavisi [Depression in pregnancy: Prevalence, risk factors and treatment]. *Psikiyatride Güncel Yaklaşımlar*, 3, 142–162.
- Yurdugül, H. (2005). Ölçek geliştirme çalışmalarında kapsam geçerliği için kapsam geçerlik indekslerinin kullanılması [Using scope validity indices for scope validation in scale development studies]. XIV. National Educational Science Congress, 28–30.
- Yüksel, F., Akın, S., & Durna, Z. (2011). Prenatal Distres Ölçeği'nin Türkçe'ye Uyarlanması ve Faktör Analizi [Adaptation of revised version of prenatal distress questionnaire into Turkish: reliability and validity study and factor analysis]. *HEAD*, 8, 43–51.